



INSTALLATION MANUAL

VOICE SECURITY SYSTEM

VS-900

Be sure to leave system installations, adjustments, and data settings to the dealer from whom you have purchased.

Please follow the instructions in this manual to obtain the optimum results from this unit. We also recommend that you keep this manual handy for future reference.

TOA Corporation

TABLE OF CONTENTS

1. SAFETY PRECAUTIONS	4
2. FCC REQUIREMENTS	6
3. INDUSTRIAL CANADA REQUIREMENTS	7
4. GENERAL DESCRIPTION	8
5. FEATURES	8
6. INSTALLATION PRECAUTIONS	8
7. SYSTEM CONFIGURATION AND EQUIPMENT FUNCTIONS	
7.1. System Configuration	9
7.2. Equipment Functions	10
8. VS-900MF MAIN FRAME NOMENCLATURE AND FUNCTIONS	12
9. INSTALLATION AND CONNECTION PROCEDURES	13
10. EQUIPMENT INSTALLATION	
10.1. VS-900MF Main Frame	
10.1.1. Rack mounting	14
10.1.2. Wall mounting	15
10.2. PU-200 Power Transformer unit	
10.2.1. Rack mounting	16
10.2.2. Wall mounting	17
10.3. RS-150, RS-160, RS-170, RS-180 and RS-190 Substations	18
10.4. RS-191 Option Handset (Indoor type)	
10.4.1. Wall mounting	19
10.4.2. RS-190 and RS-191 connection	19
10.5. Master Station	
10.5.1. Desk-top mounting	20
10.5.2. Wall mounting	20
10.6. VS-900SC Site Connector	
10.6.1. Rack mounting	21
10.6.2. Mounting to the VS-900MF	21
10.6.3. Wall mounting	21
11. VS-900MF CARD INSTALLATION	
11.1. Backup Battery Installation	22
11.2. Card Installation	23
12. WIRING	
12.1. Wiring from the Station or Outside Line	24
12.2. Supplied Connector Connection	25
12.3. VS-900MS Master Station Interface Card Connection	
Installation Precaution	26
12.3.1. Master Station and VS-900MS connection, MS addressing.....	27
12.3.2. External recording device and VS-900MS connection	29

12.4. MS-900 Master Station Connection and Adjustment	
12.4.1. External speaker connection	30
12.4.2. Internal speaker volume and microphone sensitivity adjustment	30
12.5. VS-900AL Telephone Interface Card Connection	
12.5.1. Telephone and VS-900AL connection	31
12.5.2. External recording device and VS-900AL connection	33
12.6. VS-900RS Substation Interface Card Connection	
12.6.1. Substation and VS-900RS connection	34
12.6.2. External amplifier and VS-900RS connection	35
12.7. VS-910RS Substation Interface Card Connection	36
12.8. VS-900CO Outside Line Interface Card Connection	
12.8.1. Outside line and VS-900CO connection	37
12.8.2. External recording device and VS-900CO connection	38
12.9. VS-900AF Audio Function Card Connection	
12.9.1. Amplifier and VS-900AF connection	39
12.9.2. External sound source and VS-900AF connection	40
12.10. VS-900TI Tie-Line Interface Card Exchange Interconnection	41
12.11. VS-900SC Site Connector Connection	
12.11.1. Exchange connection example	44
12.11.2. Power supply connection	44
12.11.3. Connection to the VS-900TI	45
12.11.4. Connecting the VS-900SC to another VS-900SC unit	46
12.11.5. Connection to an optical/audio signal converter	46
12.12. VS-900MF Main Frame and PU-200 Power Transformer Connection	47
13. MAIN FRAME AND PC CONNECTION	
13.1. Programming PC Connection	
13.1.1. Direct connection by means of RS-232C	48
13.1.2. Connection via modem	49
13.2. Operation Log PC Connection	
13.2.1. Direct connection by means of RS-232C	50
13.2.2. Connection via modem	51
13.3. System Programming	51
14. SPEECH AND FUNCTION TESTS	
14.1. Speech Test	52
14.2. Function Test	52
15. SPECIFICATIONS	
VS-900MF Main Frame	53
VS-900MS Master Station Interface Card	53
VS-900AL Telephone Interface Card	54
VS-900RS Substation Interface Card	54
VS-910RS Substation Interface Card	55
VS-900CO Outside Line Interface Card	55
VS-900AF Audio Function Card	56
VS-900TI Tie-line Interface Card	56
VS-900SC Site Connector	57
YC-303 Main Frame Wall Mounting Bracket	57

1. SAFETY PRECAUTIONS

- Before installation or use, be sure to carefully read all the instructions in this section for correct and safe operation.
- Be sure to follow all the precautionary instructions in this section, which contain important warnings and/or cautions regarding safety.
- After reading, keep this manual handy for future reference.

Safety Symbol and Message Conventions

Safety symbols and messages described below are used in this manual to prevent bodily injury and property damage which could result from mishandling. Before operating your product, read this manual first and understand the safety symbols and messages so you are thoroughly aware of the potential safety hazards.



WARNING

Indicates a potentially hazardous situation which, if mishandled, could result in death or serious personal injury.



CAUTION

Indicates a potentially hazardous situation which, if mishandled, could result in moderate or minor personal injury, and/or property damage.



WARNING

When Installing the Unit

[Applicable to the exchange and the station]

- Do not expose the unit to rain or an environment where it may be splashed by water or other liquids, as doing so may result in fire or electric shock.
- Do not cut, kink, otherwise damage nor modify the power supply cord and connection cord. In addition, avoid using the cords in close proximity to heaters, and never place heavy objects -- including the unit itself -- on the cords, as doing so may result in fire or electric shock.

[Applicable to the exchange]

- Use the unit only with the voltage specified on the unit. Using a voltage higher than that which is specified may result in fire or electric shock.
- Be sure to ground to the safety ground (earth) terminal to avoid electric shock. Never ground to a gas pipe as a catastrophic disaster may result.
- Owing to the unit's size and weight, be sure that at least two persons are available to install the unit. Failure to do so could result in personal injury.

• (When mounted on a wall)

Refer all installation work to the dealer from whom the unit was purchased. Installation requires extensive technical knowledge and experience. The unit may fall off if incorrectly installed, resulting in possible personal injury.

• (When mounted on a wall)

Install the unit only in a location that can structurally support the weight of the unit and the mounting bracket. Doing otherwise may result in the unit falling down and causing personal injury and/or property damage.

When the Unit is in Use

[Applicable to the exchange]

- Should the following irregularity be found during use, immediately switch off the power, disconnect the power supply plug from the AC outlet and contact your nearest TOA dealer. Make no further attempt to operate the unit in this condition as this may cause fire or electric shock.
 - If you detect smoke or a strange smell coming from the unit.
 - If water or any metallic object gets into the unit
- To prevent a fire or electric shock, never open nor remove the unit case as there are high voltage components inside the unit. Refer all servicing to your nearest TOA dealer.
- Do not place cups, bowls, or other containers of liquid or metallic objects on top of the unit. If they accidentally spill into the unit, this may cause a fire or electric shock.
- Do not touch the power cord during thunder and lightning, as this may result in electric shock.



CAUTION

When Installing the Unit

[Applicable to the exchange and the station]

- Avoid installing the unit in humid or dusty locations, in locations exposed to the direct sunlight, near the heaters, or in locations generating sooty smoke or steam as doing otherwise may result in fire or electric shock.

[Applicable to the exchange]

- Do not block the ventilation slots in the unit's cover. Doing so may cause heat to build up inside the unit and result in fire.

When the Unit is in Use

[Applicable to the exchange]

- Do not place heavy objects on the unit as this may cause it to fall or break which may result in personal injury and/or property damage. In addition, the object itself may fall off and cause injury and/or damage.
- Contact your TOA dealer as to the cleaning. If dust is allowed to accumulate in the unit over a long period of time, a fire or damage to the unit may result.

2. FCC REQUIREMENTS

- (1) This equipment complies with Part 68 of the FCC rules. On the front panel of this equipment is a label that contains, among other information, the FCC registration number and ringer equivalence number (REN) for this equipment. If requested, this information must be provided to the telephone company.
- (2) USOC Jack RJ11C or RJ11W
- (3) This Equipment is designed to be connected to the telephone network or premises wiring using a compatible modular jack that is Part 68 compliant. See this manual (VS-900 INSTALLATION MANUAL) for details.
- (4) The REN is used to determine the quantity of devices that may be connected to the telephone line. Excessive REN's on the telephone line may result in the devices not ringing in response to an incoming call. Typically, the sum of REN's should not exceed five (5.0). To be certain of the number of devices that may be connected to a line (as determined by the total REN's), contact the local telephone company.
- (5) If this equipment VS-900 causes harm to the telephone network, the telephone company will notify you in advance that temporary discontinuance of service may be required. But if advance notice isn't practical, the telephone company will notify the customer as soon as possible. Also, you will be advised of your right to file a complaint with the FCC if you believe it is a necessary.
- (6) The telephone company may make changes in its facilities, equipment, operations, or procedures that could affect the operation of the equipment. If this happens, the telephone company will provide advance notice in order for you to make the necessary modifications in order to maintain uninterrupted service.
- (7) If trouble is experienced with this equipment VS-900, please contact TOA Electronics, Inc., 601 Gateway Boulevard, Suite 300, South San Francisco, CA. 94080, phone (800) 733-4748 for repair and warranty information. If the trouble is causing harm to the telephone network, the telephone company may request you remove the equipment from the network until the problem is resolved.
- (8) This equipment may not be used on coin service provided by the telephone company. Connection to party lines is subject to state tariffs.
- (9) This equipment is hearing aid compatible.

WARNING (For U.S.A. only)

This equipment generates, uses, and can radiate radio frequency energy and, if not installed and used in accordance with the instructions manual, may cause interference to radio communications. It has been tested and found to comply with the limits for a Class A computing device pursuant to Subject J of Part 15 of the FCC Rules, which are designed to provide reasonable protection such interference when operated in a commercial environment.

Operation of this equipment in a residential area is likely to cause interference, in which case the user at his own expense will be required to take whatever measures may be required to correct the interference.

3. INDUSTRIAL CANADA REQUIREMENTS

EQUIPMENT ATTACHMENT LIMITATIONS

"NOTICE: The Industry Canada label identifies certified equipment. This certification means that the equipment meets telecommunications network protective, operational and safety requirements as prescribed in the appropriate Terminal Equipment Technical Requirements document(s). The Department does not guarantee the equipment will operate to the user's satisfaction.

Before installing this equipment, users should ensure that it is permissible to be connected to the facilities of the local telecommunications company. The equipment must also be installed using an acceptable method of connection. The customer should be aware that compliance with the above conditions may not prevent degradation of service in some situations.

Repairs to certified equipment should be coordinated by a representative designated by the supplier. Any repairs or alterations made by the user to this equipment, or equipment malfunctions, may give the telecommunications company cause to request the user to disconnect the equipment.

Users should ensure for their own protection that the electrical ground connections of the power utility, telephone lines and internal metallic water pipe system, if present, are connected together. This precaution may be particularly important in rural areas.

Caution: Users should not attempt to make such connections themselves, but should contact the appropriate electric inspection authority, or electrician, as appropriate."

"NOTICE: The **Ringer Equivalence Number** (0.4) assigned to each terminal device provides an indication of the maximum number of terminals allowed to be connected to a telephone interface. The termination on an interface may consist of any combination of devices subject only to the requirement that the sum of the Ringer Equivalence Numbers of all the devices does not exceed 5."

RESTRICTIONS CONCERNANT LE RACCORDEMENT DE MATÉRIEL

"AVIS: L'étiquette d'Industrie Canada identifie le matériel homologué. Cette étiquette certifie que le matériel est conforme aux normes de protection, d'exploitation et de sécurité des réseaux de télécommunications, comme le prescrivent les documents concernant les exigences techniques relatives au matériel terminal. Le Ministère n'assure toutefois pas que le matériel fonctionnera à la satisfaction de l'utilisateur.

Avant d'installer ce matériel, l'utilisateur doit s'assurer qu'il est permis de le raccorder aux installations de l'entreprise locale de télécommunication. Le matériel doit également être installé en suivant une méthode acceptée de raccordement. L'abonné ne doit pas oublier qu'il est possible que la conformité aux conditions énoncées ci-dessus n'empêche pas la dégradation du service dans certaines situations.

Les réparations de matériel homologué doivent être coordonnées par un représentant désigné par le fournisseur. L'entreprise de télécommunications peut demander à l'utilisateur de débrancher un appareil à la suite de réparations ou de modifications effectuées par l'utilisateur ou à cause de mauvais fonctionnement.

Pour sa propre protection, l'utilisateur doit s'assurer que tous les fils de mise à la terre de la source d'énergie électrique, des lignes téléphoniques et des canalisations d'eau métalliques, s'il y en a, sont raccordés ensemble. Cette précaution est particulièrement importante dans les régions rurales.

Avertissement: L'utilisateur ne doit pas tenter de faire ces raccordements lui-même; il doit avoir recours à un service d'inspection des installations électriques, ou à un électricien, selon le cas."

"AVIS: L'indice d'équivalence de la sonnerie (0.4) assigné à chaque dispositif terminal indique le nombre maximal de terminaux qui peuvent être raccordés à une interface. La terminaison d'une interface téléphonique peut consister en une combinaison de quelques dispositifs, à la seule condition que la somme d'indices d'équivalence de la sonnerie de tous les dispositifs n'excède pas 5."

This Class A digital apparatus complies with Canadian ICES-003.

Cet appareil numérique de la classe A est conforme à la norme NMB-003 du Canada.

4. GENERAL DESCRIPTION

The VS-900 Security System is a voice communication system that permits calls to be quickly and easily made - even in emergency situations - with the touch of single button. The system can record conversations, and features external equipment sync output and operation log output. These features combine to make the VS-900 an ideal system for voice security applications.

5. FEATURES

- Modular construction facilitates installation, maintenance, and system expansion.
- Rack- or wall-mountable exchange.
- Up to 4 master stations (or commercial telephone sets) and 64 substations can be connected per exchange.
- Up to 2 outside telephone (C/O) lines can be connected per exchange.
- Station paging (by means of the substation speaker) and external paging functions.
- External sound source distribution capability.
- Up to 19 paging zones can be established.
- Emergency Paging function.
- By connecting an external recording device, the conversations at the master station (or telephone set) and at the outside line telephone can be recorded.
- Exchange operating log can be transmitted to a PC.
- Tie-line possible for up to 16 exchanges.
- 24 V DC input for connection of backup power supply.
- Manual/Automatic Call Forwarding, Conference, Scan Monitor functions.

6. INSTALLATION PRECAUTIONS

- Make sure that the power is switched OFF during installation work. Switch on the power after the installation work is completed.
- To prevent the unit's failure, be sure to switch off its power when inserting or removing the card.
- When mounting each card, fully insert it into the Main Frame. After all cards are mounted, secure them with the card fixing bracket.
- Do not use the unit near heaters or in locations exposed to sunlight. The unit's plastic parts may be deformed or its finish discolored.
- Avoid installing the unit in humid or dusty locations, as doing otherwise may cause the unit's failure.
- When the unit gets dirty with dust or oil, wipe down with a soft, dry cloth. Never use a chemically-treated cleaning cloth or volatile liquids, such as benzine and thinner, because the unit's plastic parts may be deformed or its finish discolored.

7. SYSTEM CONFIGURATION AND EQUIPMENT FUNCTIONS

7.1. System Configuration

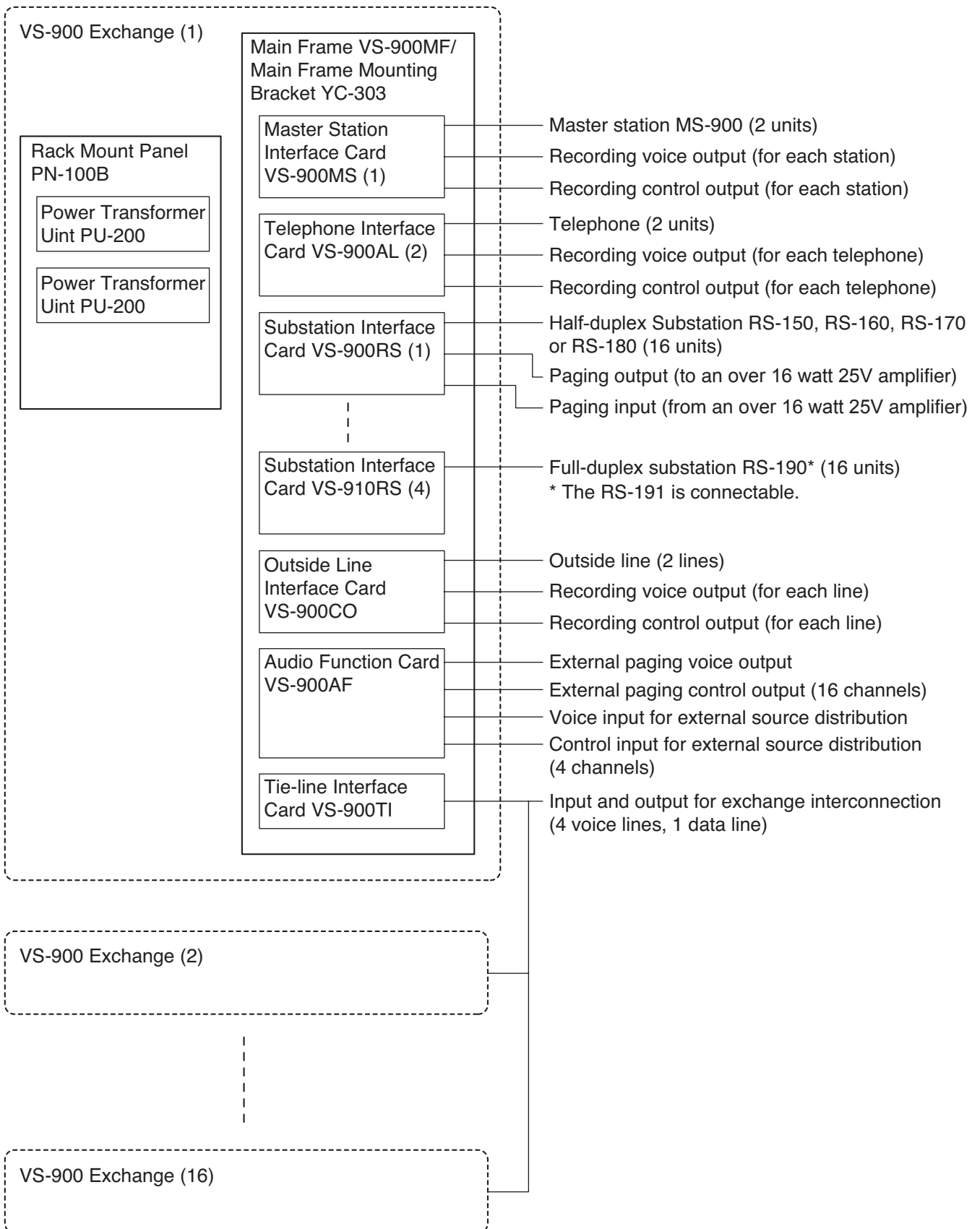

7.2. Equipment Functions

- **VS-900MF Main Frame**

The VS-900MF accommodates the following cards: Up to 2 VS-900MS or VS-900AL Cards (both cards may be mixed), up to 4 VS-900RS or VS-910RS Cards (both cards may be mixed), 1 VS-900CO Card, 1 VS-900AF Card, and 1 VS-900TI Card.

The Main Frame has 2 RS-232C ports; one for programming and the other for operation log output.

- **VS-900MS Full-duplex Master Station Interface Card**

The VS-900MS is used for master station connection. Up to 2 master stations can be connected per card, and an external recording device can be connected to each line.

- **VS-900AL Telephone Interface Card**

The VS-900AL is used for connecting telephone sets (in compliance with the FCC Regulation Part 68). Up to 2 telephones can be connected per card, and an external recording device can be connected to each line.

- **VS-900RS Half-duplex Remote Substation Interface Card**

The VS-900RS is used for substation connection. Up to 16 substations can be connected per card. The Substation Interface Card has 2 speech links, one of which also functions as a paging link with the paging input/output connected to an external amplifier.

- **VS-910RS Full-duplex Remote Substation Interface Card**

The VS-910RS is used for connecting full-duplex substations and option handsets. Up to 16 substations can be connected per card. The Substation Interface Card has 2 speech links, one of which also functions as a paging link with the paging input/output connected to an external amplifier.

- **VS-900CO Outside Telephone Line Interface Card**

The VS-900CO is used for outside telephone line connection. Up to 2 outside lines can be connected per card, and an external recording device can be connected to each line.

- **VS-900AF Audio Function Card**

The VS-900AF enables Conference, External Amplifier Paging, and External Source Distribution functions. The Audio Function Card has 1 conference link (maximum 4 stations), 1 audio output and 16 control outputs for external amplifier paging, and 1 audio input and 4 control inputs for external source distribution.

- **VS-900TI Tie-Line Interface Card**

The VS-900TI is used to interconnect multiple exchanges. The Tie-Line Interface Card can connect up to 4 links made up by 1 (STP) shielded, twisted pair of data lines and 4 twisted pairs of voice lines.

- **VS-900SC Site Connector**

When tie-line connecting VS-900 system exchanges, fiber optic cables can be used to extend the audio tie-line longer than the maximum distance* possible using twisted pair cable. TOA's VS-900 Site Connector is used to connect the VS-900 system exchanges to the fiber optic interface as shown in the figure on page 43.

* 1.5 km when an AWG20 twisted pair cable is used.

- **PU-200 Power Transformer Unit**

The wall-mountable PU-200 has 2 20V/2.5A AC outputs. One PU-200 unit is required when up to 2 VS-900RS Cards are installed, and 2 PU-200 units are required when 3 or 4 VS-900RS Cards are installed.

- **YC-303 Main Frame Wall Mounting Bracket**

The YC-303 is used when mounting the main frame on the wall.

- **PN-100B Rack Mount Panel**

The PN-100B provides side-by-side rack mounting capability for up to 2 PU-200 power supply units.

- **MS-900 Full-duplex Master Station**

The MS-900 can make calls to or receive calls from the substation. It utilizes 2 pairs of twisted cables.

- **RS-150 Half-duplex Remote Substation (Indoor Type)**

The RS-150 can call and converse with the registered master stations. It utilizes a single-pair shielded cable.

- **RS-160 Half-duplex Remote Substation (Indoor Vandal-Resistant Type)**
The RS-160 can call and converse with the registered master stations. It utilizes a single-pair shielded cable.
- **RS-170 Half-duplex Remote Substation (Outdoor Vandal-Resistant Type)**
The RS-170 can call and make converse with the registered master stations. It utilizes a single-pair shielded cable.
- **RS-180 Half-duplex Outdoor Panic Remote Substation (for Emergency Use)**
The RS-180 can call and converse with the registered master stations. It has an indicator lamp and a control output channel, and utilizes a single-pair shielded cable.
- **RS-190 Full-duplex Remote Substation (Indoor Type)**
The RS-190 can call and converse with the registered master stations. It has an indicator lamp and a control output channel, and utilizes 2 pairs of twisted cables. Recommended for elevators and other locations.
- **RS-191 Option Handset (Indoor Type)**
The RS-191 is used in combination with the RS-190. Lifting the handset permits handset conversation.

8. VS-900MF MAIN FRAME NOMENCLATURE AND FUNCTIONS

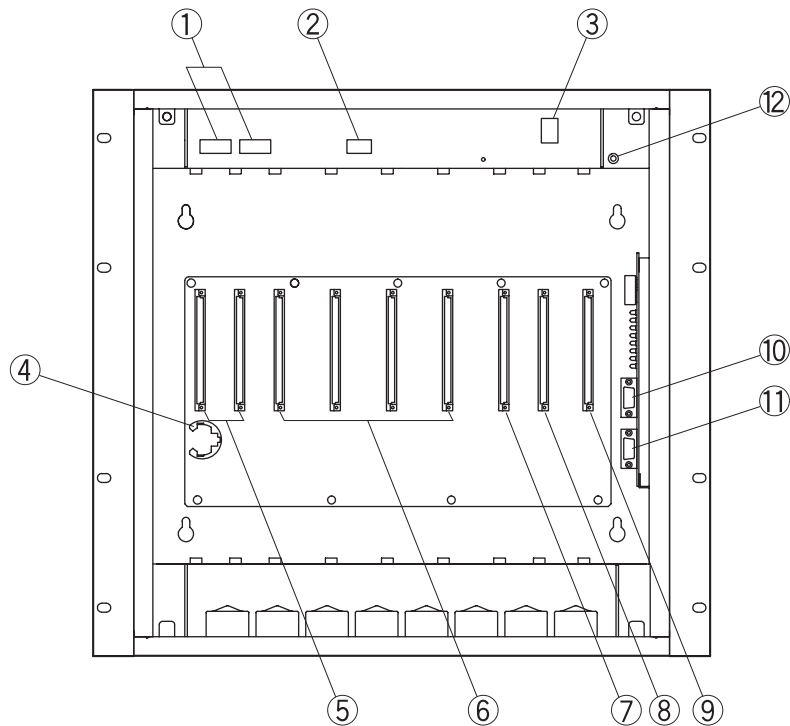

1. AC Input Connectors

Connect to the AC output terminal of the PU-200 power transformer unit. (See p. 46.)

2. 24 V DC Input Connector

Connects to a battery (24 V DC). (See p. 46.)

3. Power Switch

Power is switched on (I) and off (O) with each toggle of this switch.

4. Backup Battery Socket

Insert the CR2032 data backup battery into this socket. (See p. 22.)

5. VS-900MS/VS-900AL Installation Slot [MS/AL 1 – 2]

A maximum of 2 VS-900MS or VS-900AL cards can be installed. (See p. 27 and 32.)

6. VS-900RS/VS-910RS Installation Slot [RS 1 – 4]

A maximum of 4 VS-900RS or VS-910RS cards or combination can be installed. (See p. 33.)

7. VS-900CO Installation Slot [CO]

One VS-900CO card can be installed. (See p. 36.)

8. VS-900AF Installation Slot [AF]

One VS-900AF card can be installed. (See p. 38.)

9. VS-900TI Installation Slot [TI]

One VS-900TI card can be installed. (See p. 40.)

10. Programming PC Connector [RS-232C]

Connects to the programming PC either directly or via modem. (See p. 47.)

11. Operation Log PC Connector [RS-232C]

Connects to the operation log PC either directly or via modem. (See p. 49.)

12. Power Indicator

Lights when the power switch is set to ON.

9. INSTALLATION AND CONNECTION PROCEDURES

(1) System Design

Exchange/Station Configuration, Wiring Schedule and Station Numbering Schedule

(2) Equipment Installation

Installing the VS-900MF Main Frame in an Equipment Rack or on a Wall (See p. 14.)

Installing the PU-200 Power Transformer in an Equipment Rack or on a Wall (See p. 16.)

Installing the Remote Substation and the Option Handset (See p. 18 and 19.)

Installing the Master Station (See p. 20.)

Installing the Site Connector (See p. 21.)

(3) Installing a Card in the VS-900MF Main Frame

Installing the Data Backup Battery (See p. 22.)

Installing and Connecting Each Card (See p. 23.)

(4) Connecting the Station/Outside Line to Each Exchange Card

- MS-900 Master Station vs. VS-900MS Card (See p. 26.)
- External Recording Device vs. VS-900MS Card (See p. 29.)

- Telephone vs. VS-900AL Card (See p. 31.)
- External Recording Device vs. VS-900AL Card (See p. 33.)

- Half-duplex Remote Substation vs. VS-900RS Card (See p. 34.)
- External Amplifier vs. VS-900RS Card (See p. 35.)

- Full-Duplex Substation vs. VS-910RS Card (See p. 36.)

- Outside Line vs. VS-900CO Card (See p. 37.)
- External Recording Device vs. VS-900CO Card (See p. 38.)

- External Amplifier vs. VS-900AF Card (See p. 39.)
- External Recording Device vs. VS-900AF Card (See p. 40.)

VS-900MF Main Frame vs. PU-200 Power Transformer (See p. 47.)

(5) Tie-Line Connection (between Exchanges)

VS-900TI vs. VS-900TI (See p. 41.)

VS-900SC (See p. 44.)

(6) Connecting the VS-900MF Main Frame to a PC

Connection to a Programming PC (See p. 48.)

Connection to an Operation Log PC (See p. 50.)

Power-ON

(7) Adjusting the Station and Exchange

System Programming (See the "VS-900 SETUP SOFTWARE MANUAL.")

Master Station Microphone Sensitivity/Speaker Volume Adjustment (See p. 30.)

Telephone Volume Adjustment (VS-900AL Card) (See p. 32.)

(8) Speech and Function Tests

Speech Test (See p. 52.)

Function Test (See p. 52.)

10. EQUIPMENT INSTALLATION

10.1. VS-900MF Main Frame

10.1.1. Rack mounting

Step 1. Attach the supplied rack mounting brackets to the frame.

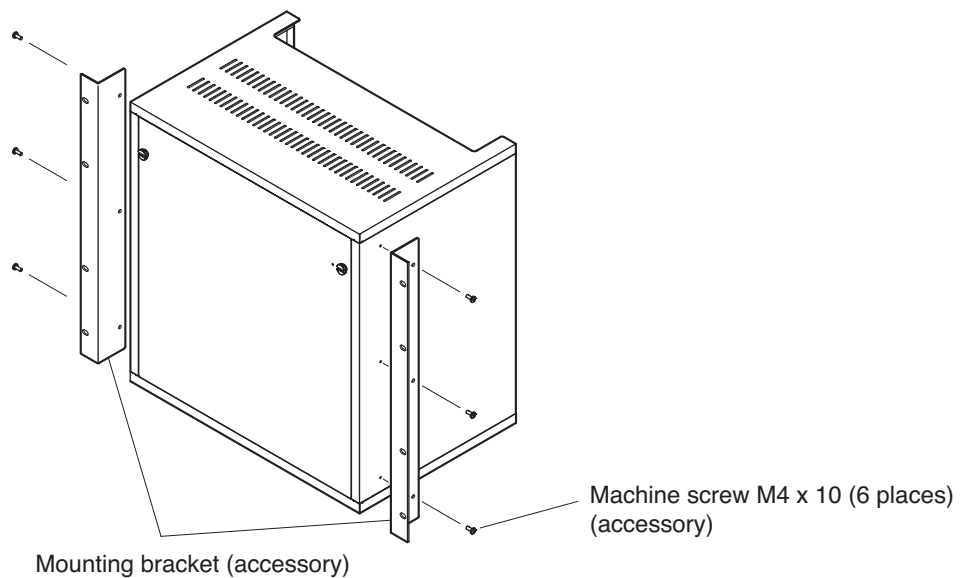

Step 2. Mount the frame to an equipment rack.

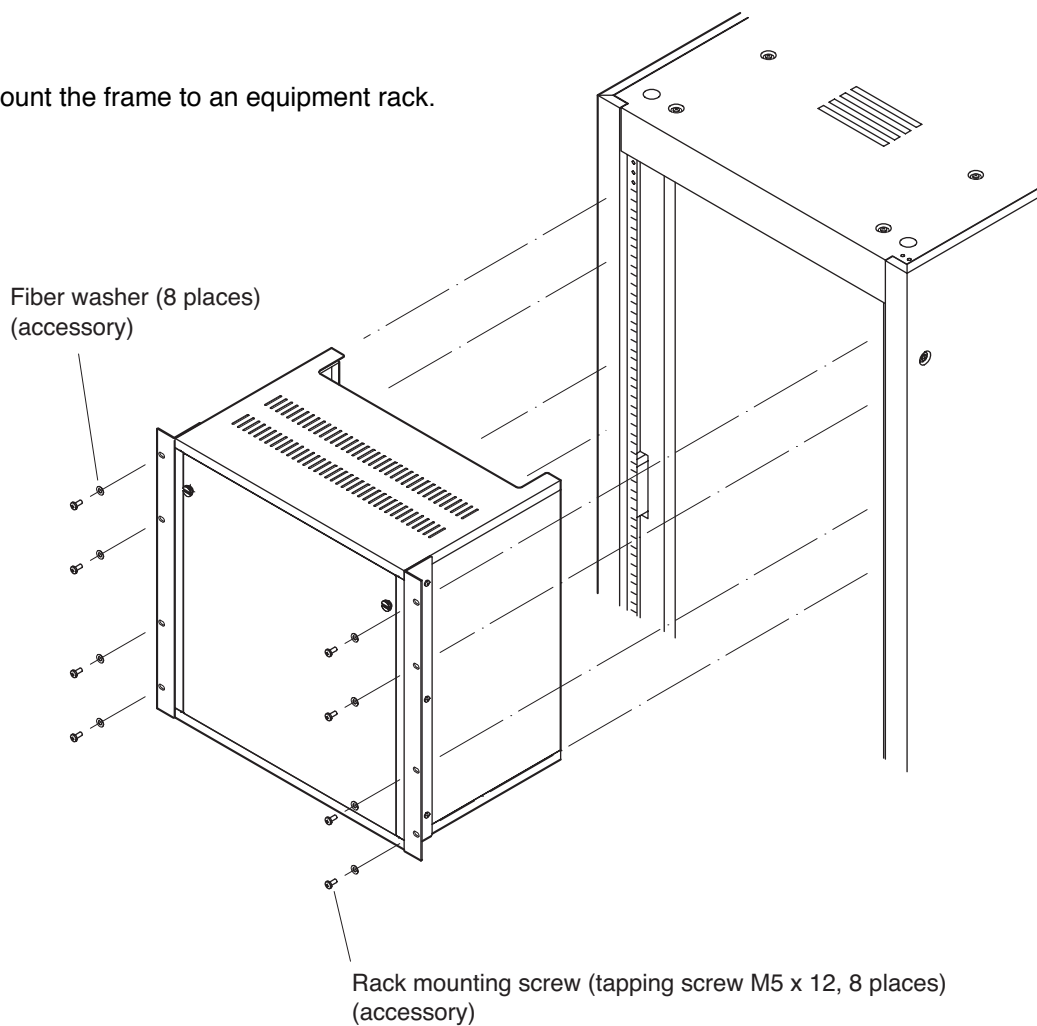

10.1.2. Wall mounting (Optional YC-303 Wall Mounting Frame is required.)

Step 1. Mount the YC-303 bracket to the wall.

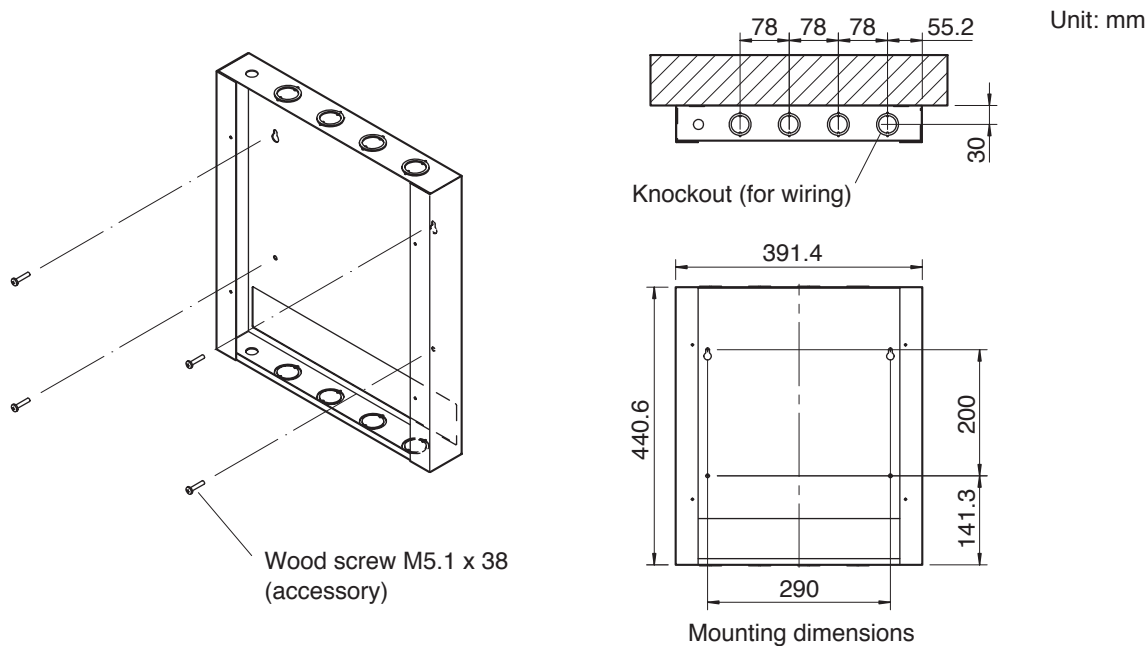

Step 2. Remove the VS-900MF's front panel, then mount the VS-900MF on the YC-303.

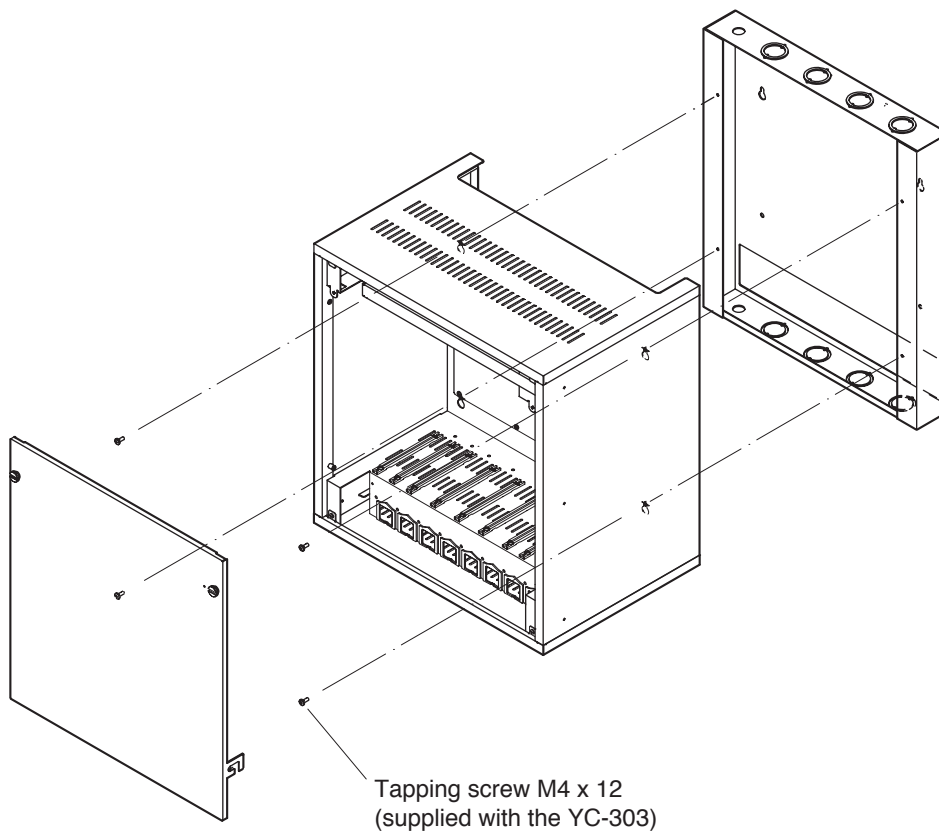

10.2. PU-200 Power Transformer Unit

10.2.1. Rack mounting

Step 1. Remove the 4 mounting screws, and attach the supplied wall mounting brackets to the transformer unit using the removed screws.

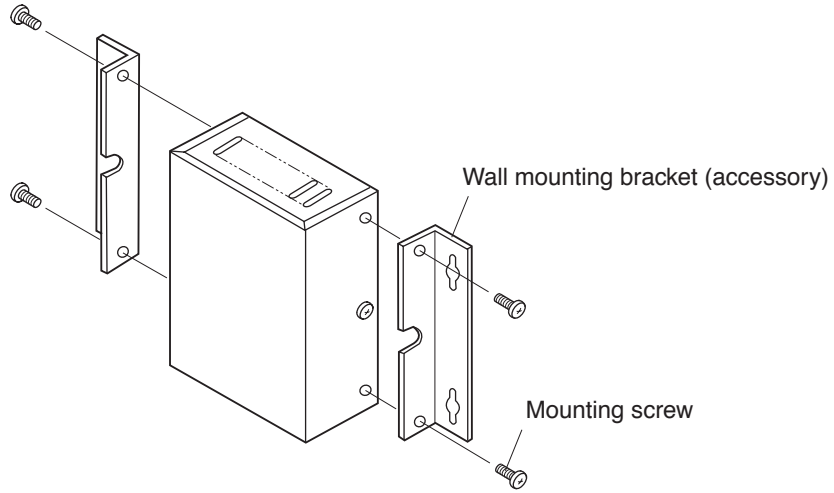

Step 2. Attach the PU-200 to the PN-100B Rack Mount Panel.

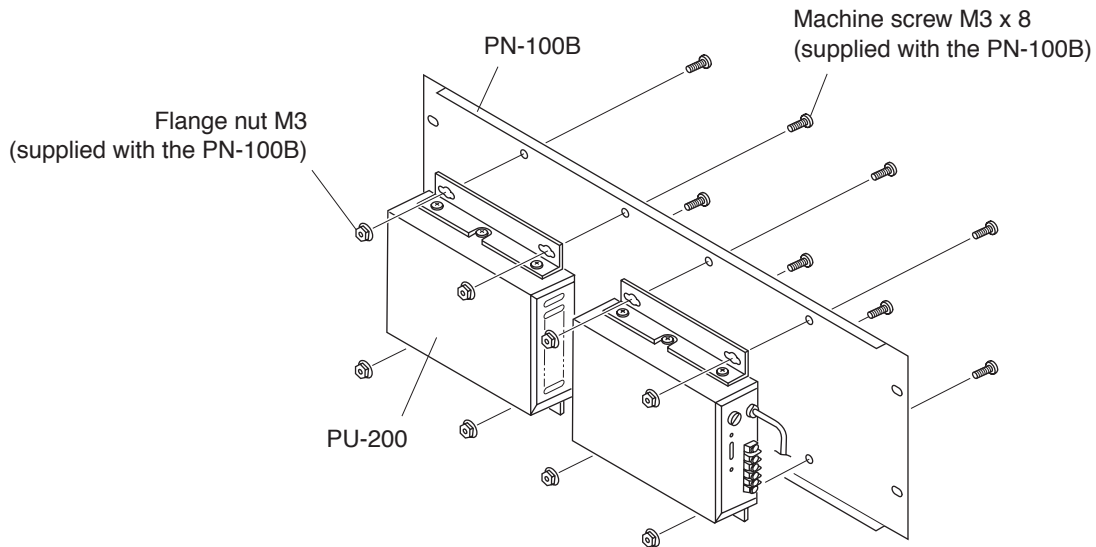

Step 3. Mount the PN-100B in an equipment rack.

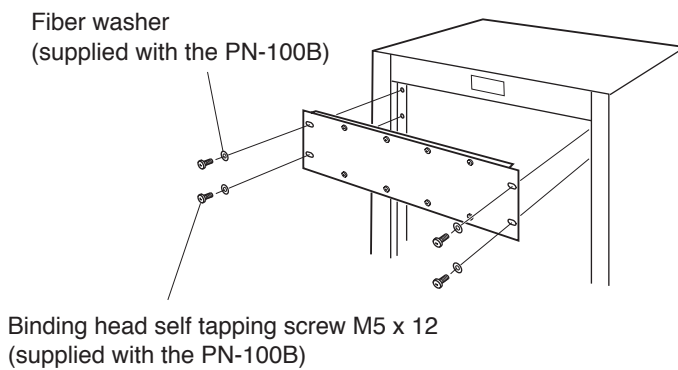

Note
Perform terminal wiring before mounting.

10.2.2. Wall mounting

Step 1. Remove the 4 mounting screws, and attach the supplied wall mounting brackets to the transformer using the removed screws.

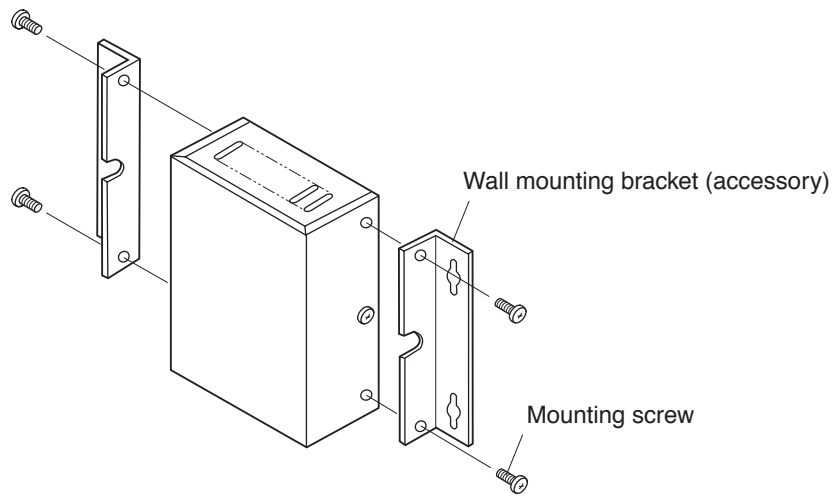

Step 2. Fix the unit on the wall. Use the supplied wood screws (3.5 x 25) as appropriate for mounting.

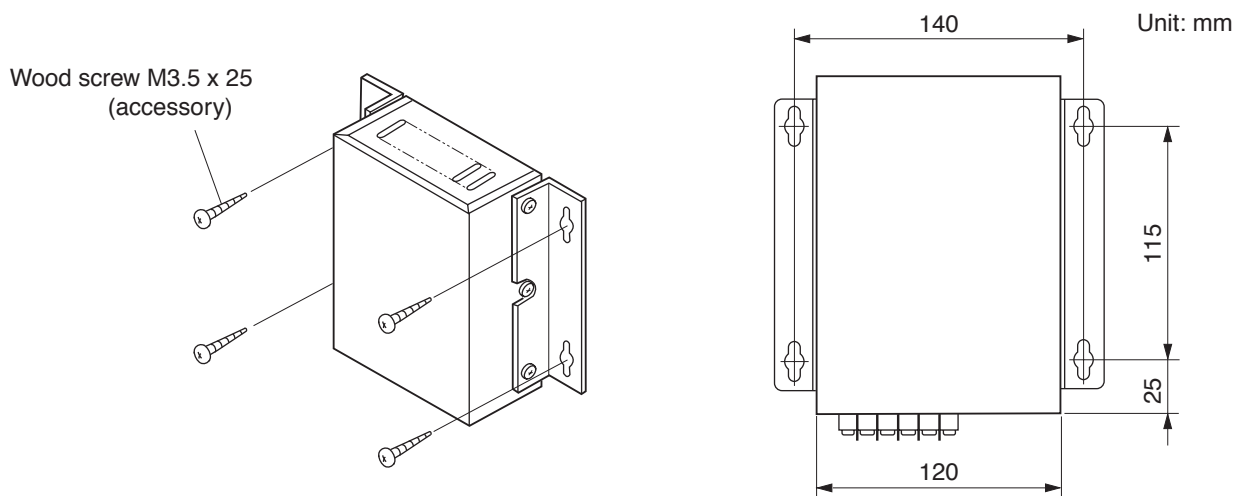

10.3. RS-150, RS-160, RS-170, RS-180 and RS-190 Substations

Mount the substation to an electrical box mounted in the wall.

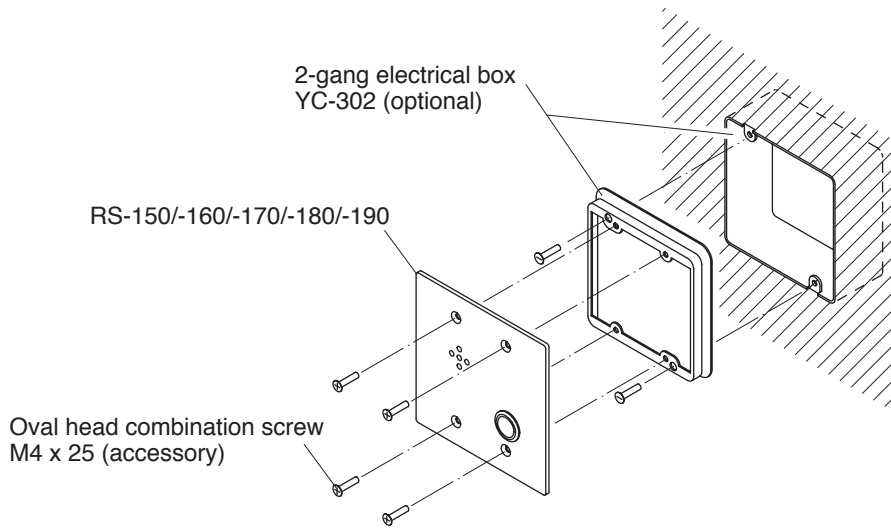

Accessory screws

The RS-150, RS-160, RS-170, RS-180 and RS-190 come with 2 types of screws: oval head combination screw M4 x 25 and oval head slotted screw UNC No.6 x 18.

For the electrical box provided with unified threads, use the oval head slotted screws UNC No.6 x 18.

Dimensional diagram

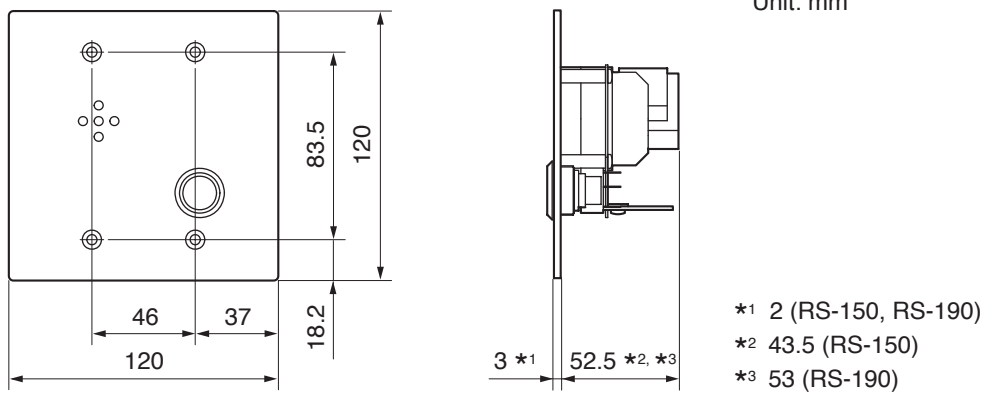

10.4. RS-191 Option Handset (Indoor type)

10.4.1. Wall mounting

Mount the option handset to an electrical box mounted in the wall.

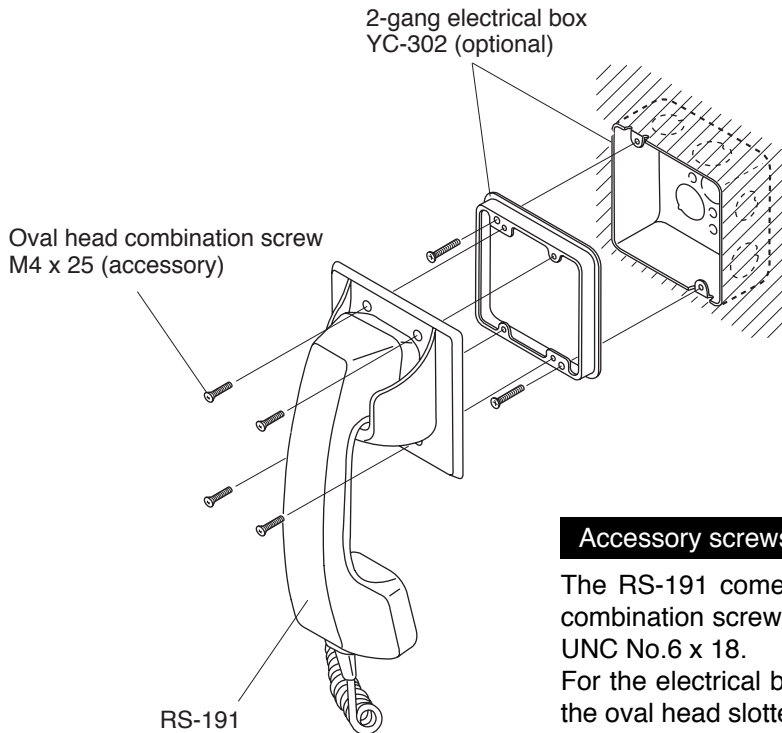

Accessory screws

The RS-191 comes with 2 types of screws: oval head combination screw M4 x 25 and oval head slotted screw UNC No.6 x 18. For the electrical box provided with unified threads, use the oval head slotted screws UNC No.6 x 18.

10.4.2. RS-190 and RS-191 connection

Plug out the jumper from the connector on the RS-190's side panel, then plug the RS-191's connection cable instead as illustrated below.

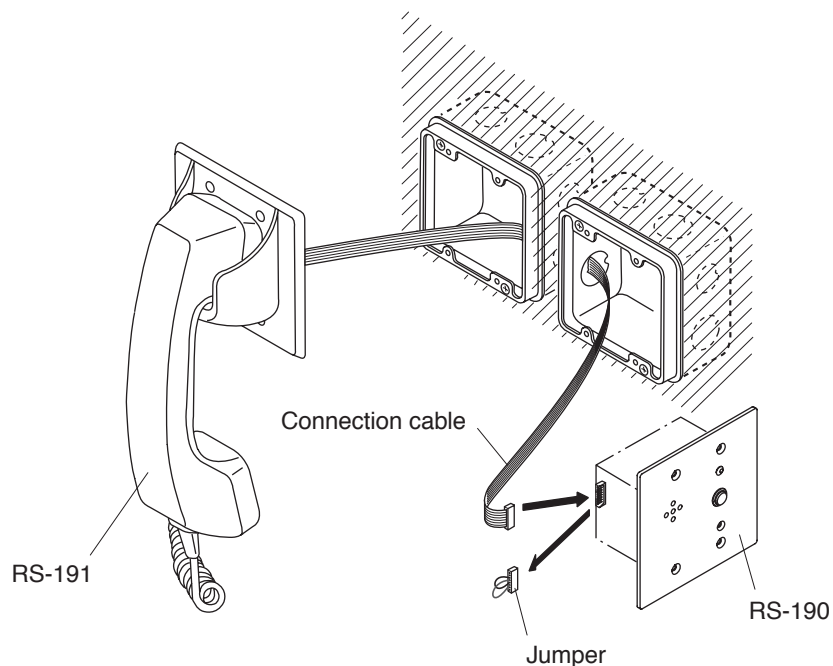

10.5. Master Station

10.5.1. Desk-top mounting

Connect the supplied modular-plug cord.

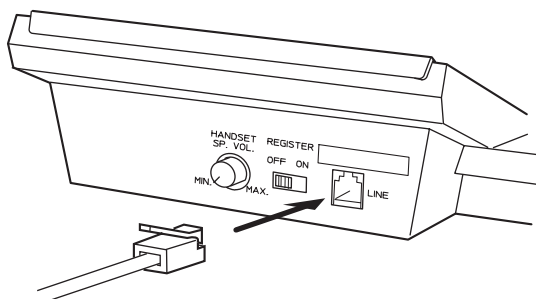

10.5.2. Wall mounting

Pull out, rotate, and reset the cradle hook, then mount the station on the wall using the supplied wall mounting frame. Use the supplied wood screws as appropriate.

Remove the cradle hook.

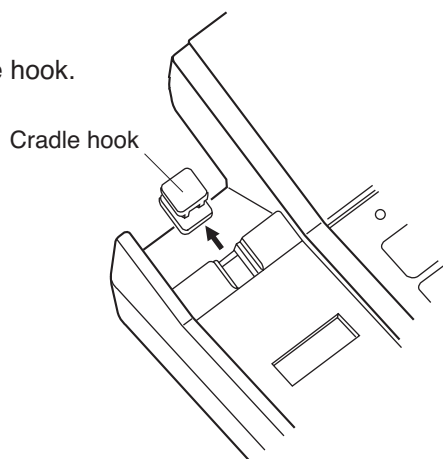

Pull out the cradle hook, then replace it after changing the direction as illustrated.

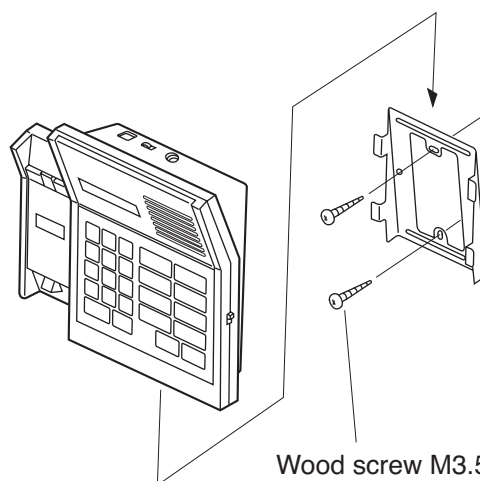
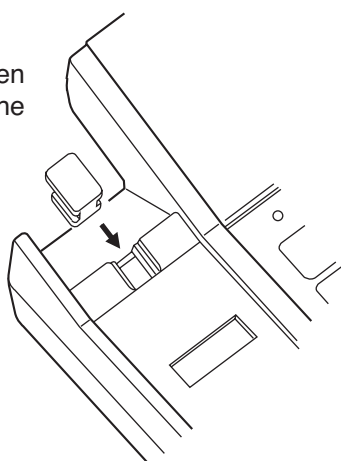

Wood screw M3.5 x 25
(supplied with the MS-900)

10.6. VS-900SC Site Connector

10.6.1. Rack mounting

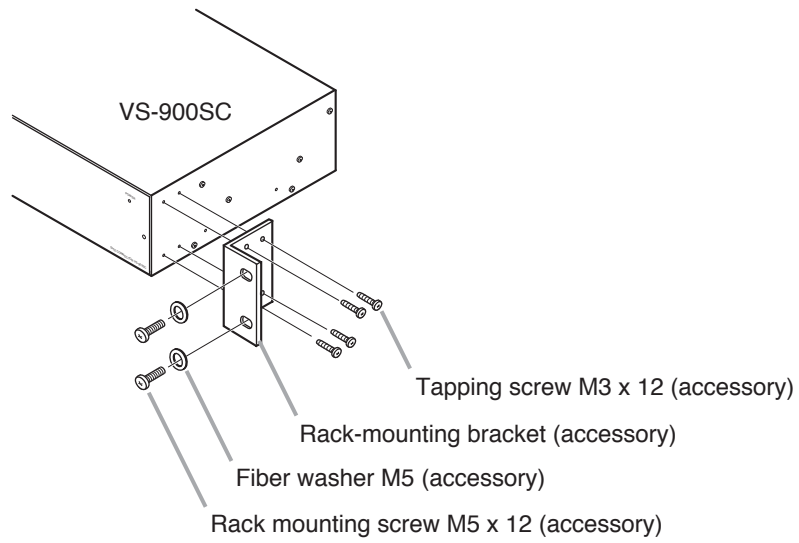

10.6.2. Mounting to the VS-900MF

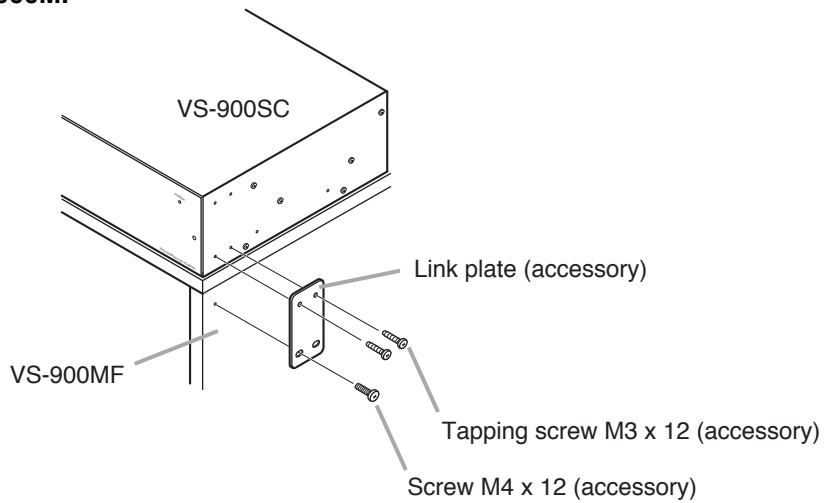

10.6.3. Wall mounting

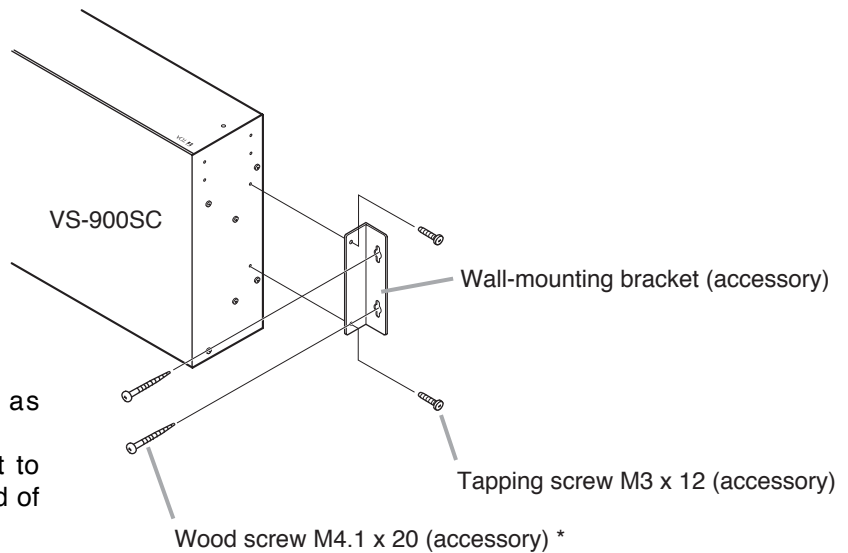

* Use the supplied wood screws as appropriate. When using them, mount the unit to wooden walls stronger than plywood of over 12 mm in thickness.

11. VS-900MF CARD INSTALLATION

11.1. Backup Battery Installation

Caution

All cards contain many CMOS ICs which are easily damaged by static electricity. Do not touch circuit components.

- Insert the backup battery into the Main Frame mother board before installing any cards.

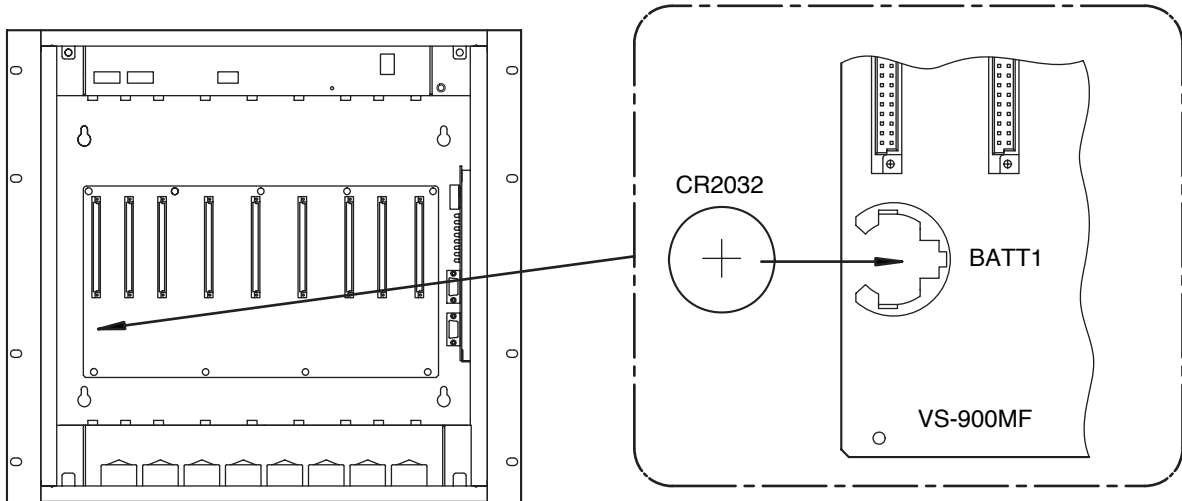

Battery replacement

As the battery life is rated at about 4 years, replace it with a new one every 4 years. Follow the replacement procedure below.

- Step 1.** Switch the Main Frame (VS-900MF) power off.
- Step 2.** Remove all installed cards.
- Step 3.** Switch the VS-900MF power on.
- Step 4.** Replace the battery.
- Step 5.** Switch the VS-900MF power off.
- Step 6.** Reinstall the removed cards.
- Step 7.** Switch the VS-900MF power on.

Important

Be sure to replace the battery while the VS-900MF power is on. Otherwise, stored time (clock) data will be lost.

CAUTION

Danger of explosion if battery is incorrectly replaced.
Replace only with the same or equivalent type recommended by the manufacturer.
Dispose of used batteries according to the manufacturer's instructions.

ATTENTION

Danger d'explosion lorsque la batterie n'est pas remplacée correctement.
Remplacer uniquement avec des batteries identiques ou d'un type équivalent.

11.2. Card Installation

Step 1. Remove each card from its static-protective bag, and install it in its designated position in the Main Frame.

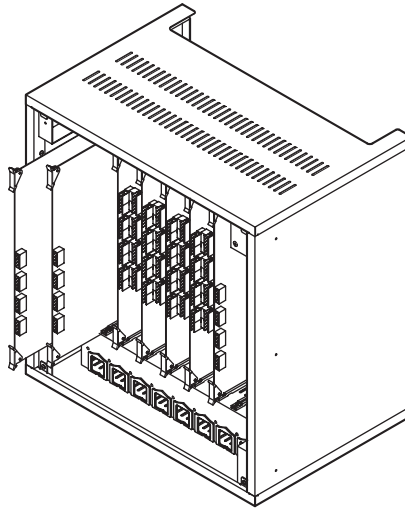

- For the VS-900TI, perform exchange number setting BEFORE installation. Refer to p. 42 "Exchange Number Setting."

Step 2. After installing all cards, secure them using the supplied fixing bracket.

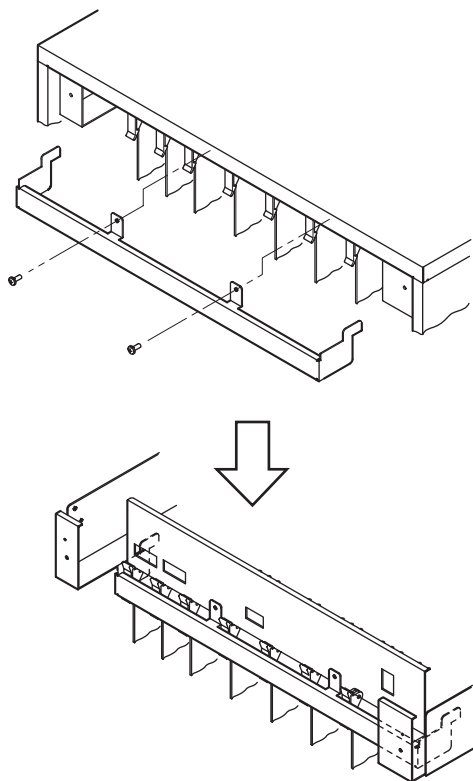

The top and side panels are omitted to show the hidden parts.

12. WIRING

12.1. Wiring from the Station or Outside Line

Step 1. Remove the main frame's bottom panel as shown below.

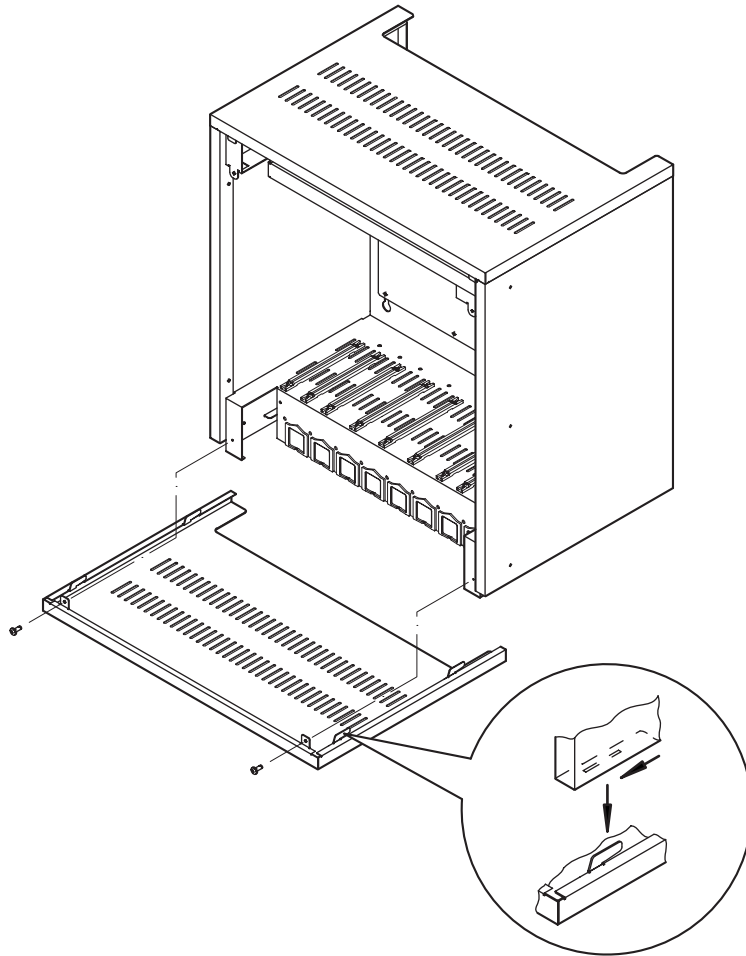

Step 2. Connect stations or outside lines to their respective cards as shown below.

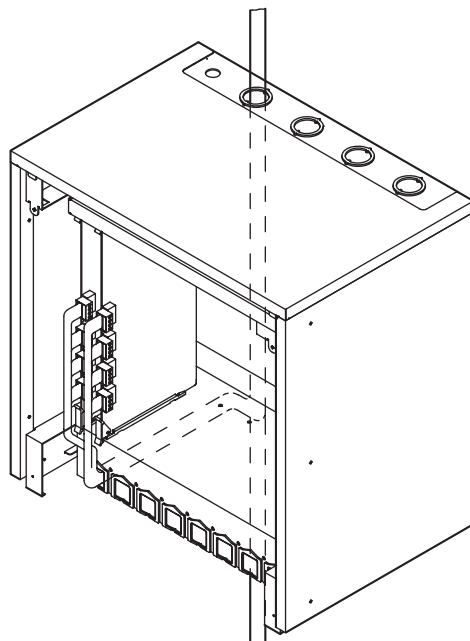

12.2. Supplied Connector Connection

Use the supplied connectors for exchange connections as follows.

Step 1. Insert a cable into the connector and tighten the screw.

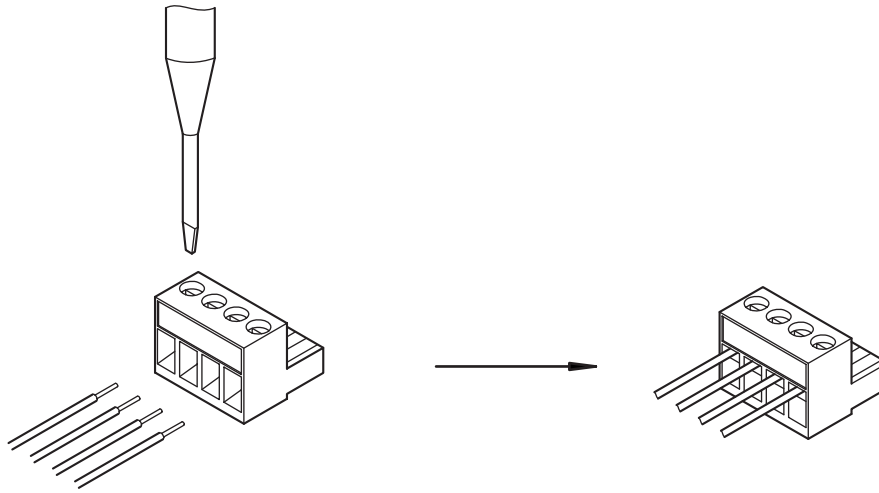

Step 2. After cable connection is completed, press the connector onto the circuit board's connector.

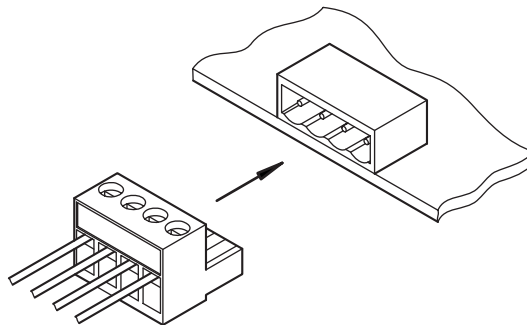

INSTALLATION PRECAUTION

Before mounting this unit to the VS-900MF Main Frame, be sure to set the DIP switch SW1 on the circuit board according to the conditions of use as shown in the table below.

Note: The previous VS-900MS does not employ the DIP switch.

[If both MS cards are new in the VS-900MF]

- If the serial number of the VS-900MF is "06G4000280" or later
Switch setting: "A" (factory-preset)
- If the serial number of the VS-900MF is earlier than "06G4000280" Switch setting: "B"

[If mixing old and new cards in the VS-900MF]

Switch setting: "B"

DIP switch SW1 setting	1	2	3
A (factory-preset)	ON	OFF	OFF
B	OFF	ON	ON

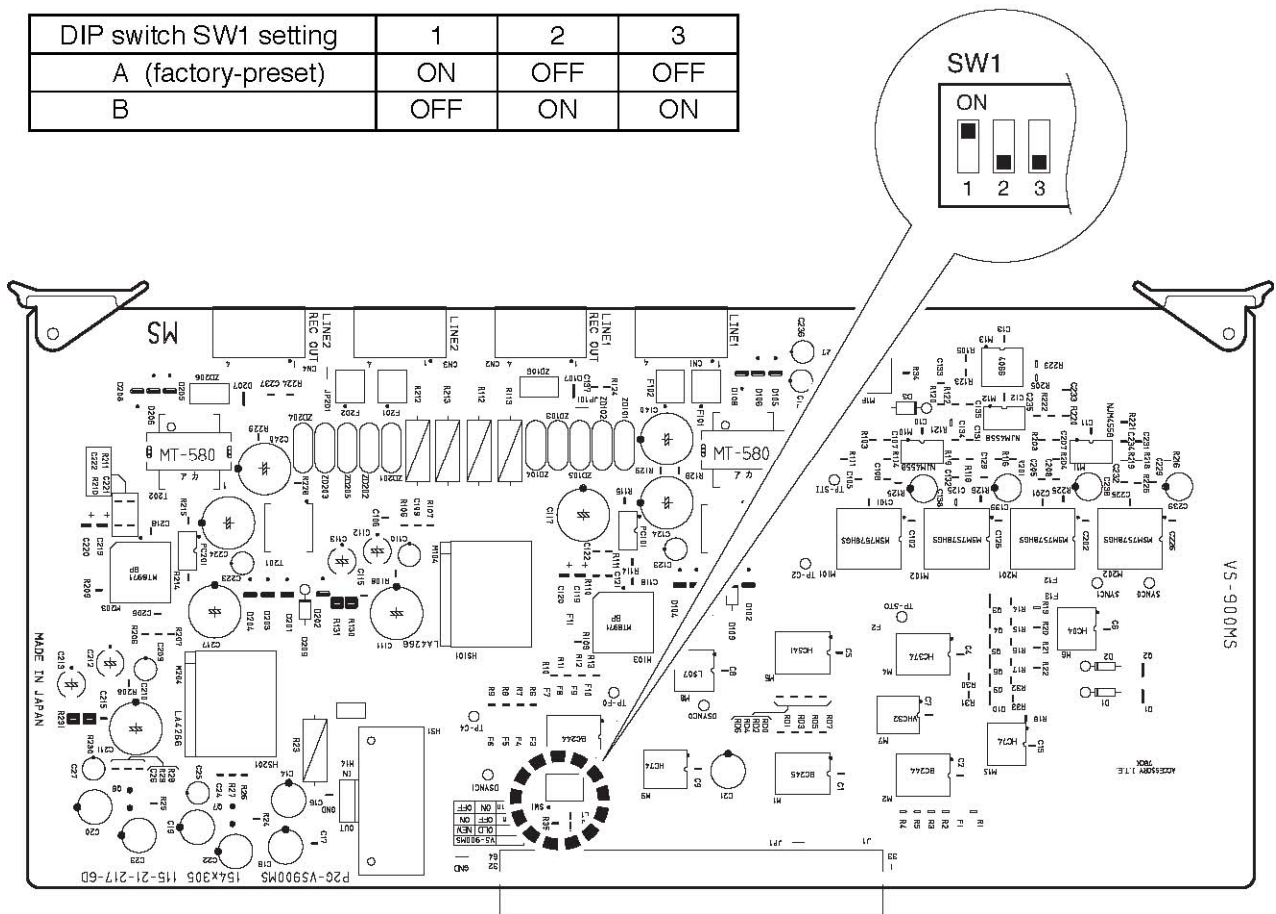

12.3. VS-900MS Master Station Interface Card Connection

12.3.1. Master Station and VS-900MS connection

- The VS-900MS can be interfaced with up to 2 MS-900 master stations.
- Because up to 2 VS-900MS cards can be mounted in the VS-900MF Main Frame, up to four master stations can be connected per frame.
- A station address must be assigned to each connected MS-900 station. Set the station address at each MS-900 station after switching ON the power.

[Station Address Setting]

Step 1. Set the Master Station's REGISTER switch to the ON position. The "Reg_mode" indication will be displayed on the station screen.

Step 2. Press the [XFER] key.

Step 3. According to the following table, enter the station address 1 – 4 through the use of a numeric keypad.

VS-900MS	Line	Station Address
MS/AL Slot 1	1	1
	2	2
MS/AL Slot 2	1	3
	2	4

Step 4. Press the [PTT] key.

Step 5. Set the REGISTER switch to the OFF position to places the station in standby mode.

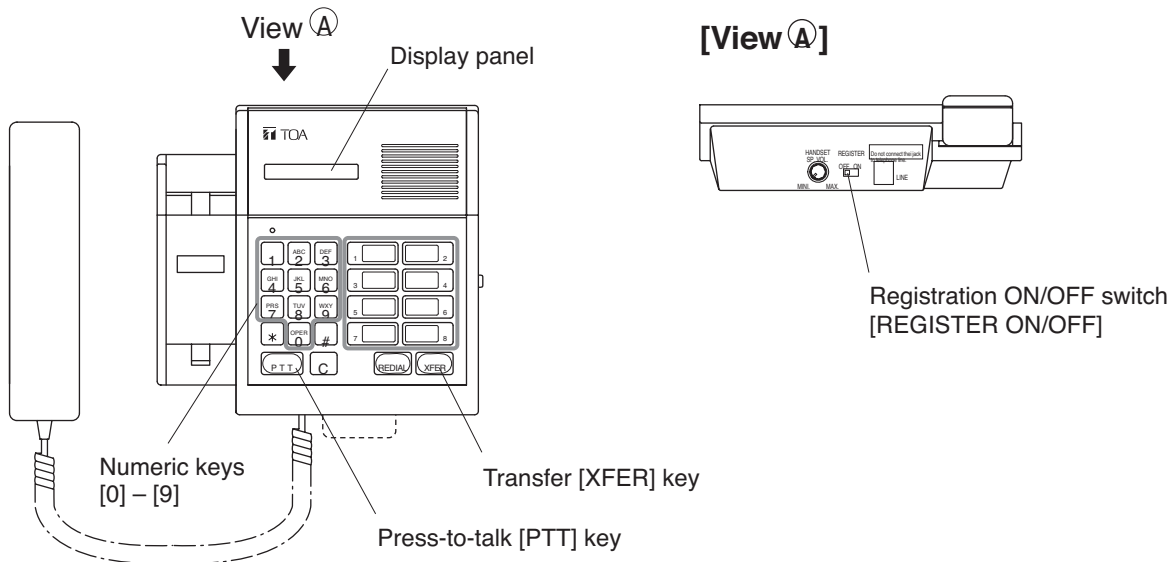

[Connection]

- Connect the MS-900 to the VS-900MS using 2 twisted pair cables as shown below referring to the following procedures.
 1. Fit the 4P connector (supplied with the VS-900MS) to one cable end, and a 6-position 4-contact modular jack (prepare locally) to the other cable end.
 2. Connect the modular jack to the MS-900's modular jack using the modular cord (supplied with the MS-900).
- The table below shows the maximum cable distance.

Cable type	AWG24 (0.52 mm)	AWG22 (0.65 mm)	AWG20 (0.82 mm)
Distance	0.9 km / 2,952 ft	1.5 km / 4,921ft	2.3 km / 7,546 ft

Connect as shown below.

VS-900MS and MS-900 connection

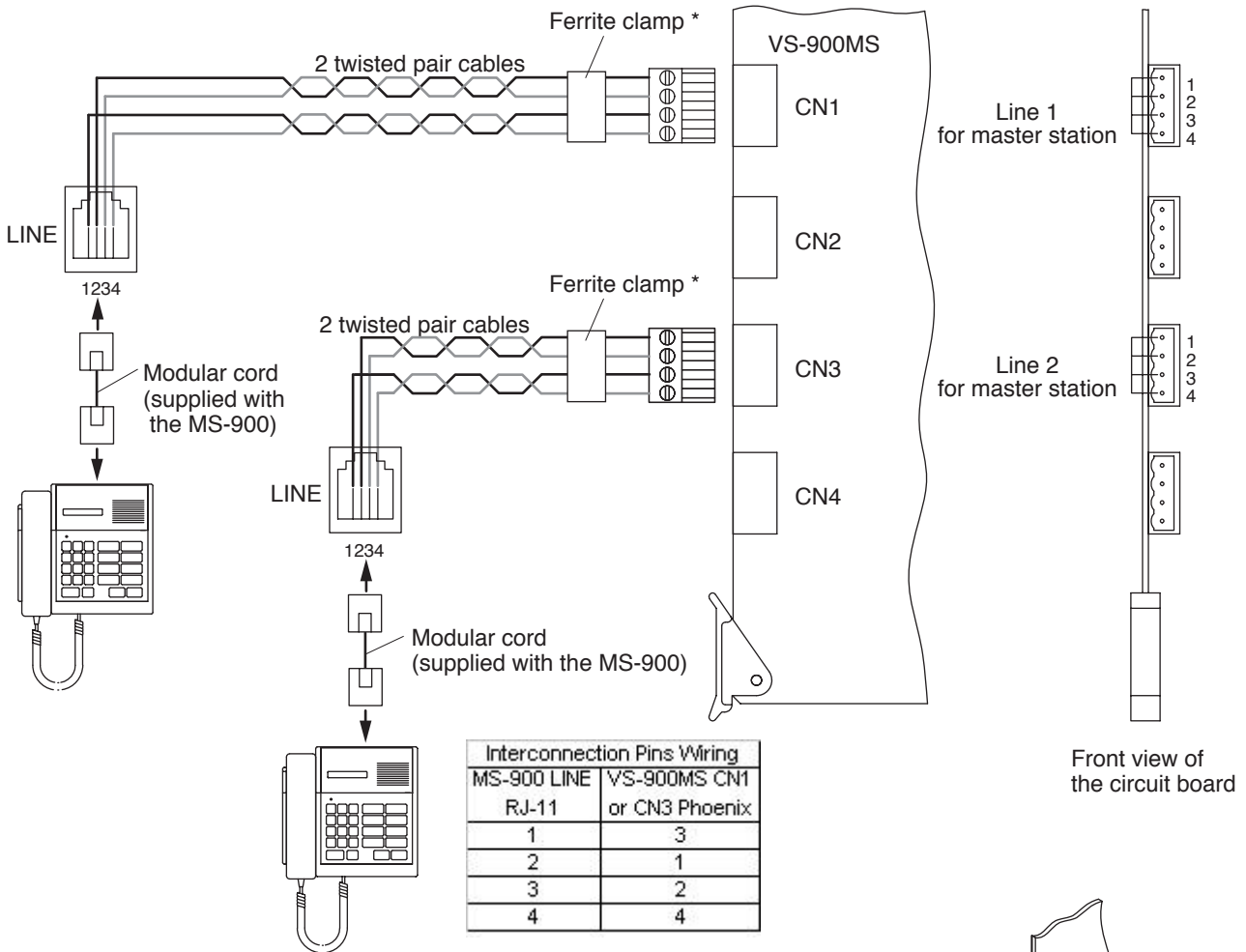

* Mount the ferrite clamp (supplied with the VS-900MS card) on the cable in a way that the cable is looped one turn as illustrated. (This countermeasure is for complying with the CE marking and FCC requirements.)

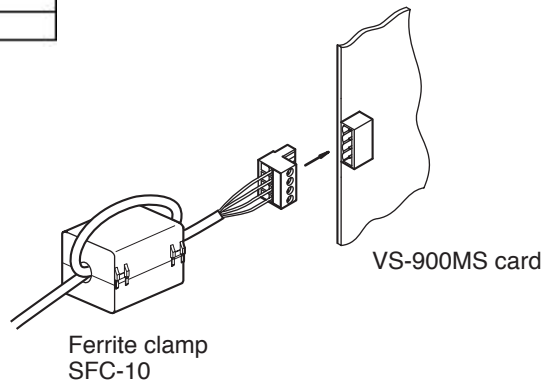

Note

When using a shielded cable, connect the shielded wire to the "FG" terminal of the exchange main frame. Also, connect the unused cables, if included in a bundle of cables, to the same terminal.

12.3.2. External recording device and VS-900MS connection

An external recording device can be connected to each master station line.

[Connection]

To connect the external recording device, use a twisted pair cable for audio output, and a twisted pair cable for control output. The audio output is 0 dB* and of unbalanced type. The control output is an open collector output 20 mA, 24 V DC max. Connect as shown below.

* 0 dB = 1 V

External recording device and VS-900MS connection

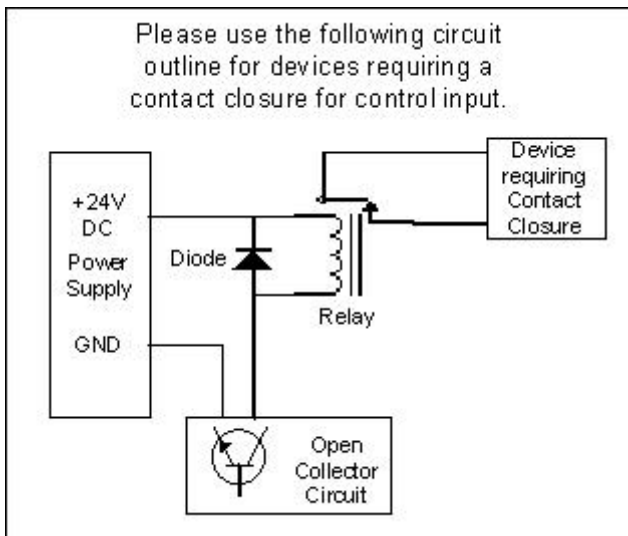
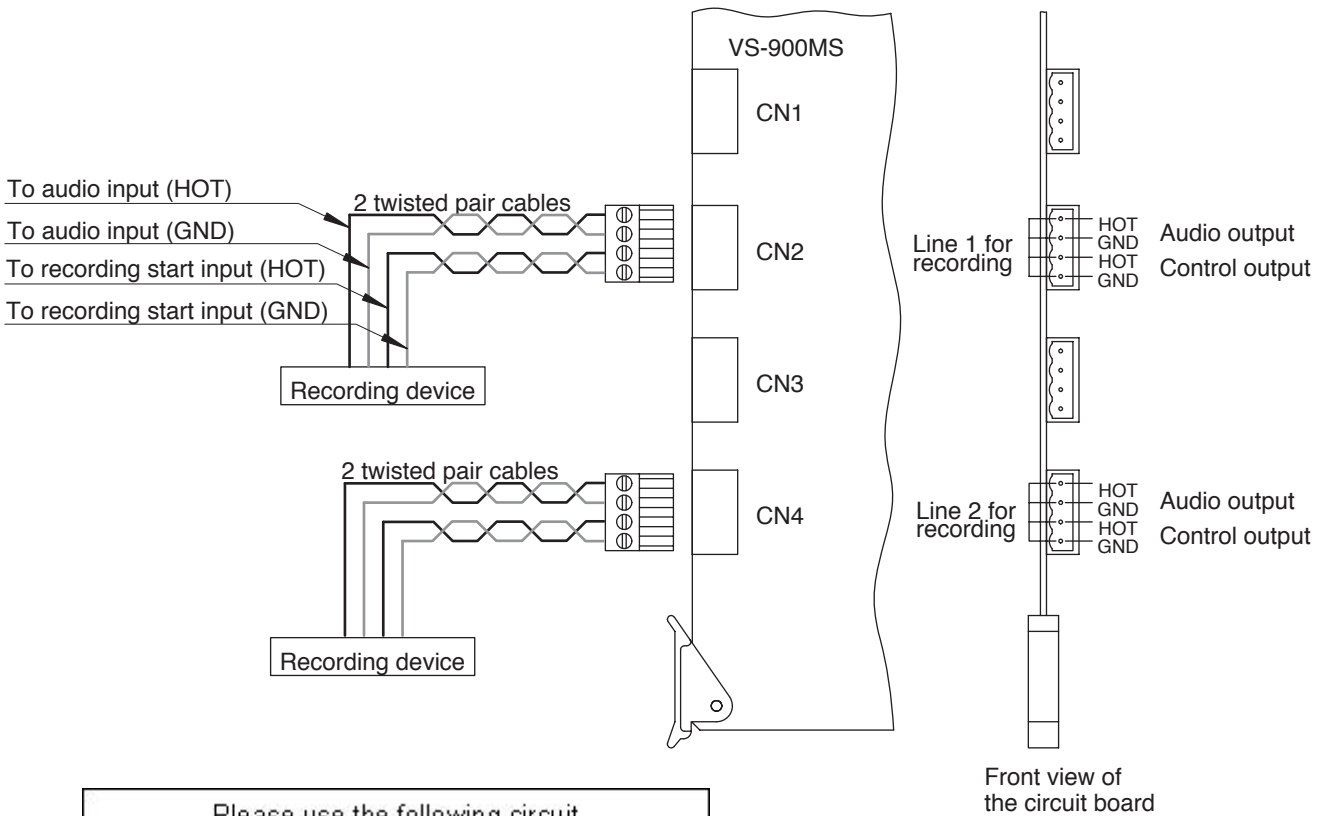

12.4. MS-900 Master Station Connection and Adjustment

12.4.1. External speaker connection

Follow the procedures below when connecting an external speaker (8 Ω).

Step 1. Remove the MS-900's rear terminal cover and set the internal slide switch to the [EXT. SP] position.

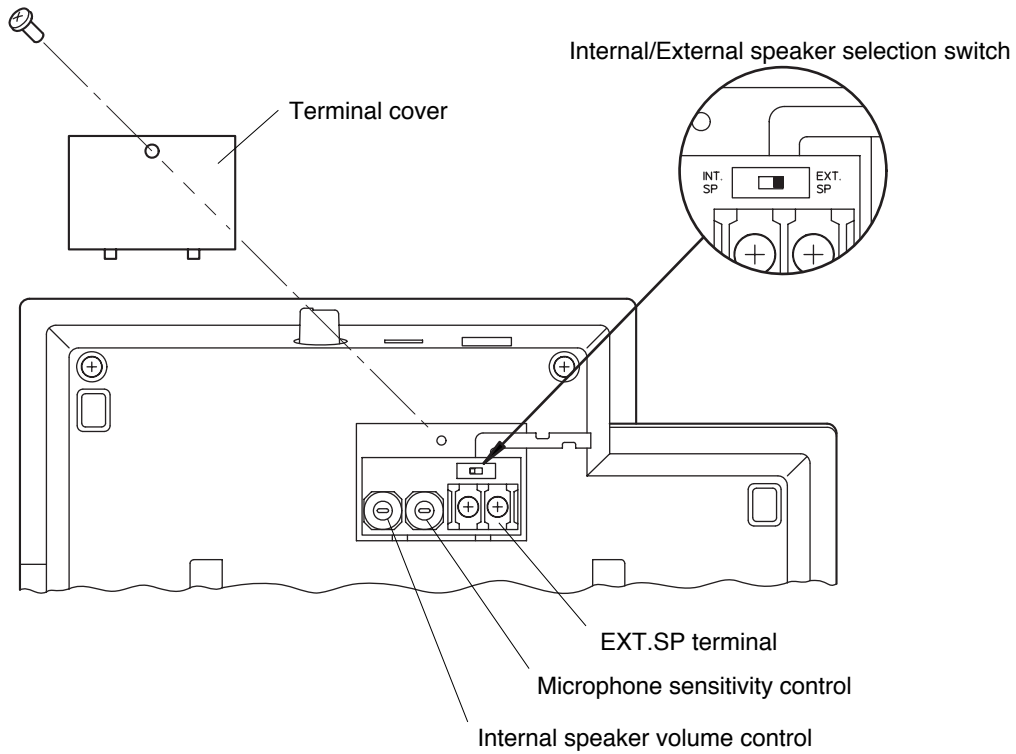

Step 2. Connect the speaker cable to EXT.SP terminal.

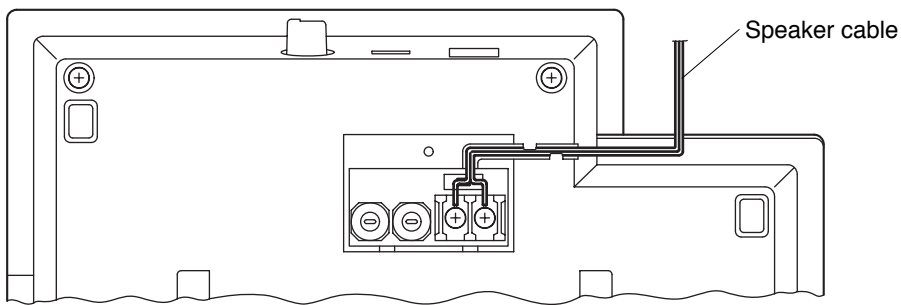

Step 3. Replace the removed terminal cover in place.

12.4.2. Internal speaker volume and microphone sensitivity adjustment

The MS-900's internal speaker volume and microphone sensitivity can be adjusted by means of their respective controls located under the terminal cover described above. Both controls are factory-preset to their maximum positions.

12.5. VS-900AL Telephone Interface Card Connection

12.5.1. Telephone and VS-900AL connection

The VS-900AL can be interfaced with up to 2 commercial telephone sets. Use the telephone which complies with the FCC Regulation Part 68.

[Connection]

To connect the telephone set to the VS-900AL, use a twisted pair cable. The connector of the cable end going to the telephone needs to be the type that can be connected to the telephone connector. Perform wiring as shown below so that the loop resistance is less than 500 Ω including the telephone resistance.

Telephone and VS-900AL connection

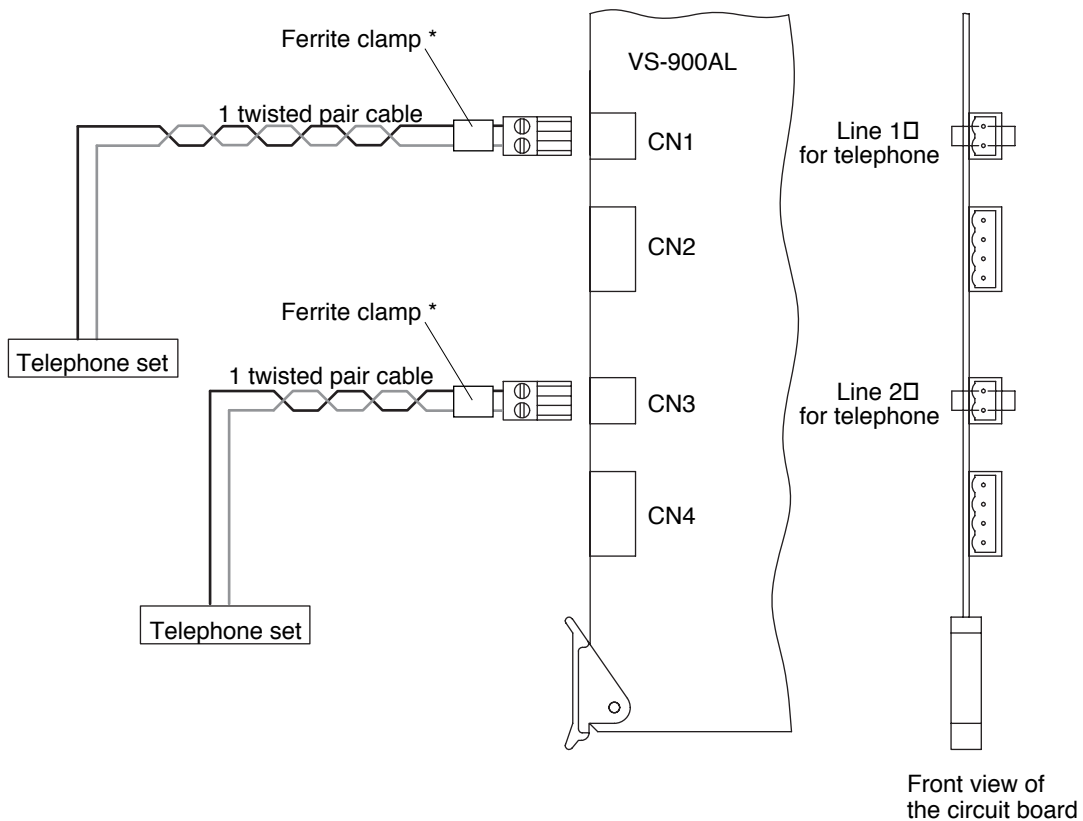

* Mount the ferrite clamp (supplied with the VS-900AL card) on the cable in a way that the cable is looped one turn as illustrated. (This countermeasure is for complying with the CE marking and FCC requirements.)

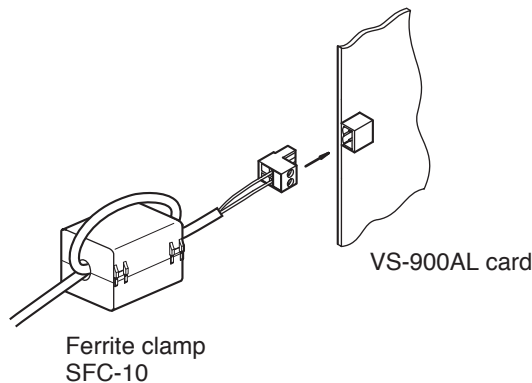

Note

When using a shielded cable, connect the shielded wire to the "FG" terminal of the exchange main frame. Also, connect the unused cables, if included in a bundle of cables, to the same terminal.

[Setting telephone's talking volume levels]

When the talking volume is low, set it using the switch SW101 (for Line 1) or SW201 (for Line 2) on the VS-900AL card as illustrated below.

Setting of telephone volume switches on the VS-900AL card

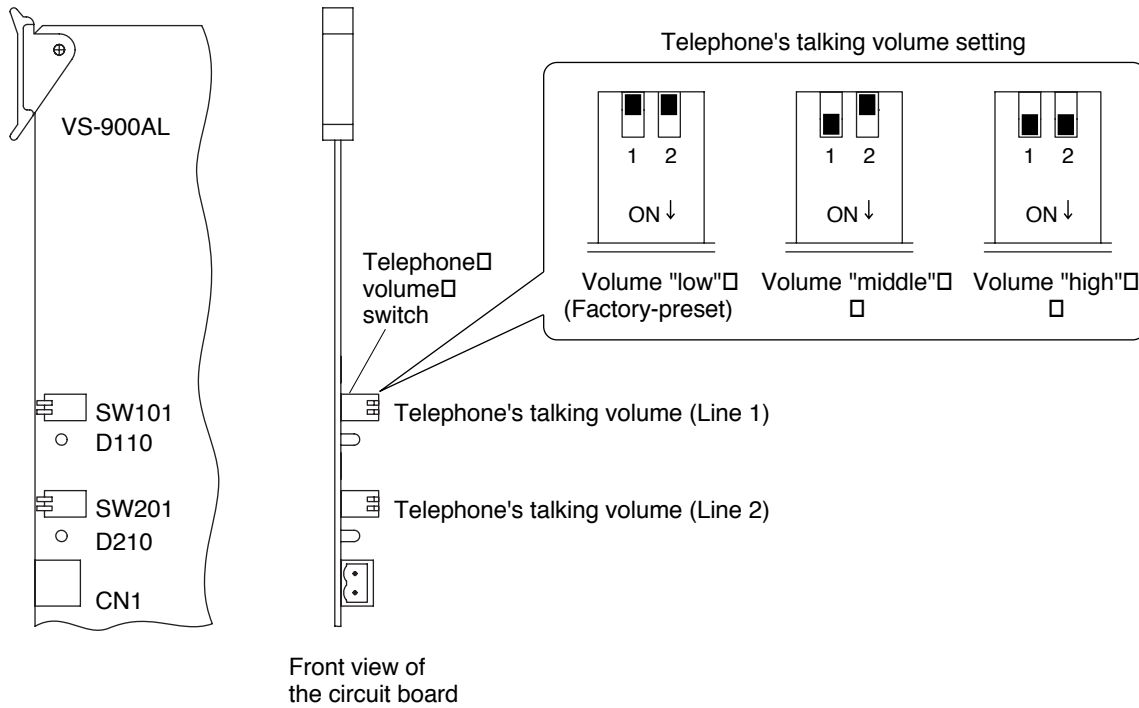

12.5.2. External recording device and VS-900AL connection

An external recording device can be connected to each telephone line.

[Connection]

To connect the external recording device, use a twisted pair cable for audio output, and a twisted pair cable for control output. The audio output is 0 dB* and of unbalanced type. The control output is an open collector output of 20 mA, 24 V DC max. Connect as shown below.

* 0 dB = 1 V

External recording device and VS-900AL connection

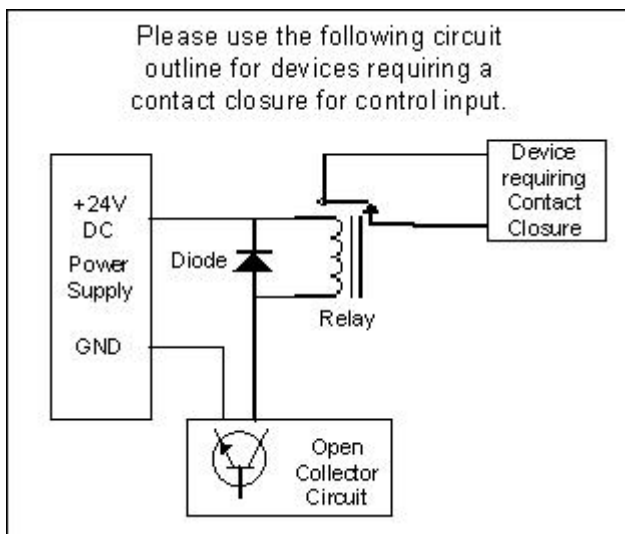
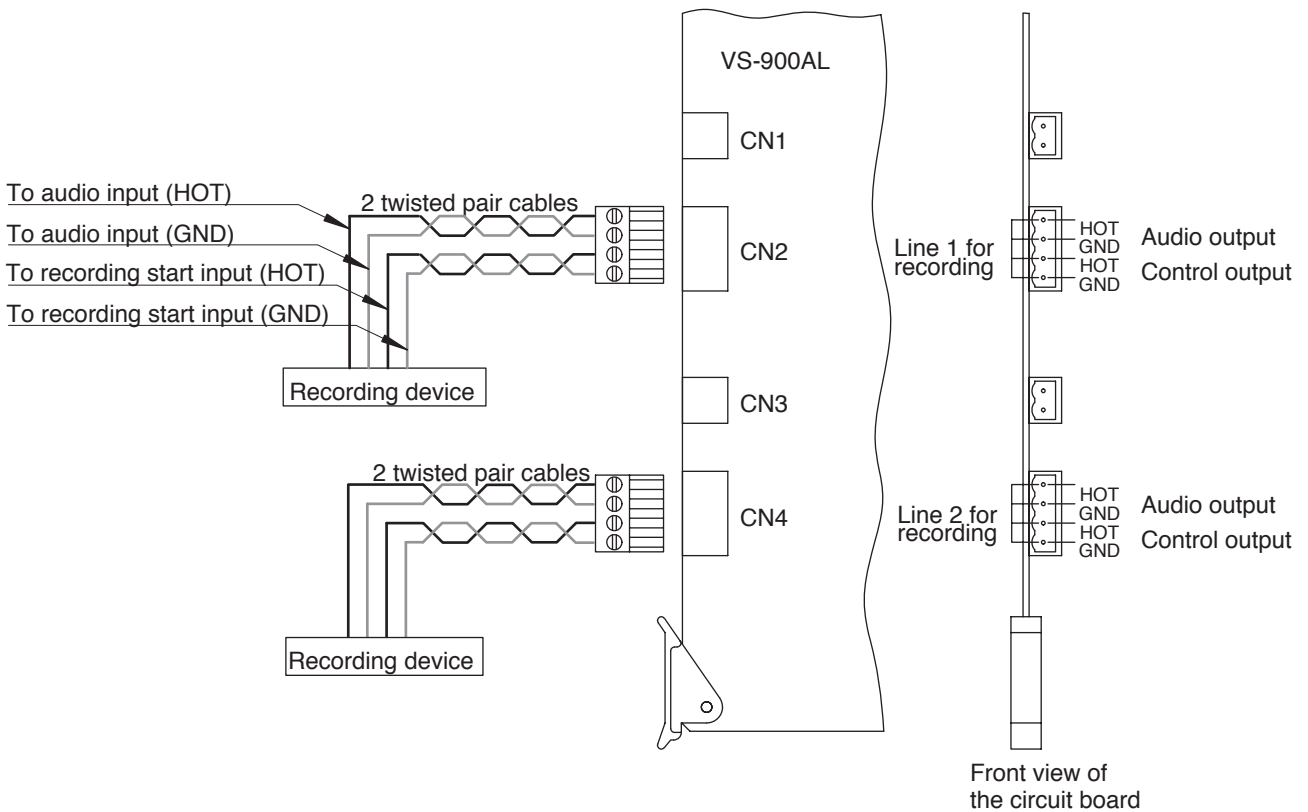

12.6. VS-900RS Remote Sub-station Interface Card Connection

12.6.1. Substation and VS-900RS connection

The VS-900RS can be interfaced with up to 16 substations.

[Connection]

Use a (STP) shielded, twisted pair cable to connect the sub-station to the VS-900RS. Refer to the following table for the maximum recommended cable length between the two.

Cable type	AWG24 (0.52 mm)	AWG22 (0.65 mm)	AWG20 (0.82 mm)
Distance	0.5 km / 1,640 ft	0.8 km / 2,624 ft	1.3 km / 4,265 ft

Connect as shown below.

Connection of the RS-150/-160/-170/-180 to the VS-900RS

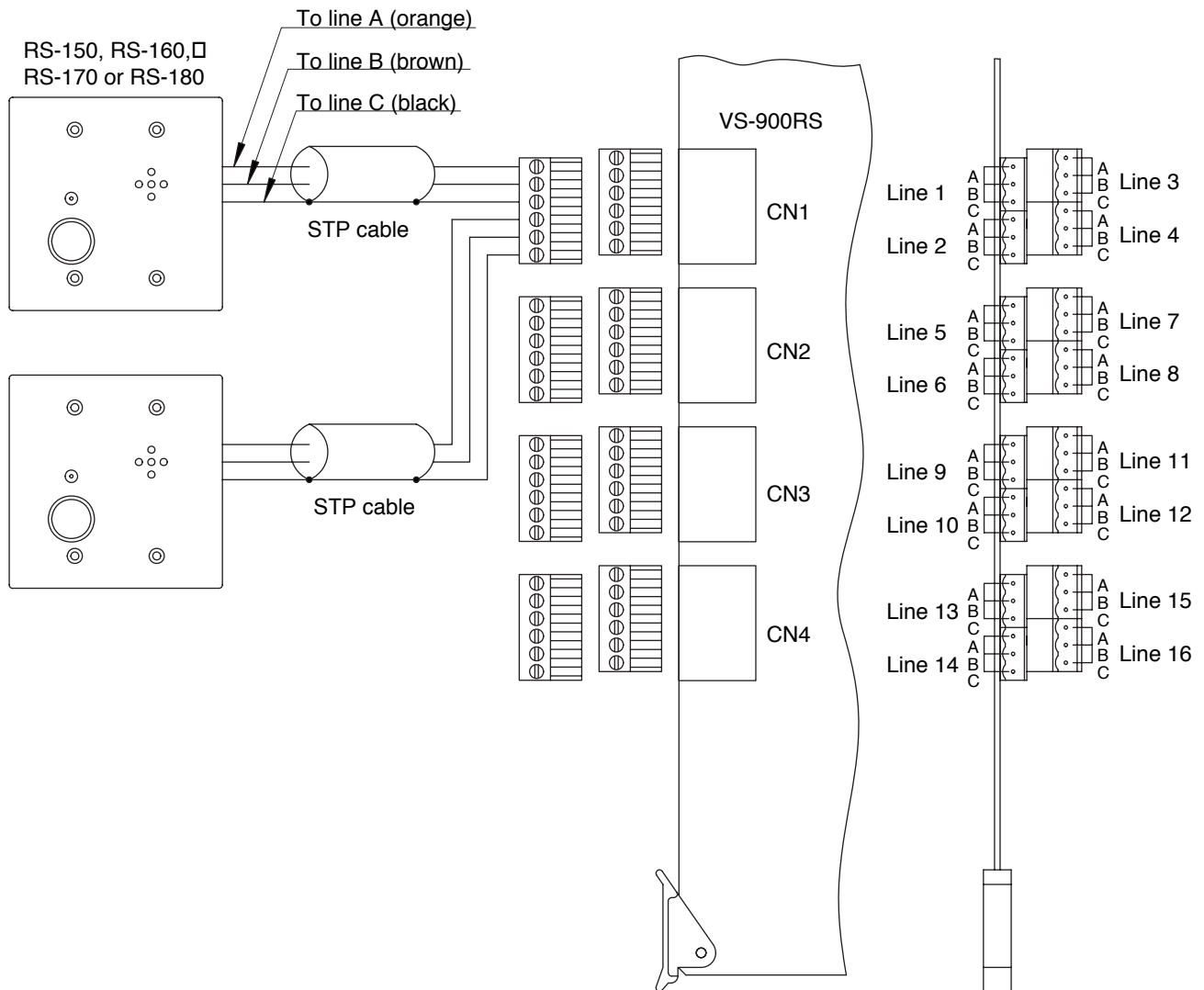

Note

The cables coming from the remote sub-stations are bared at their ends.

12.6.2. External amplifier and VS-900RS connection

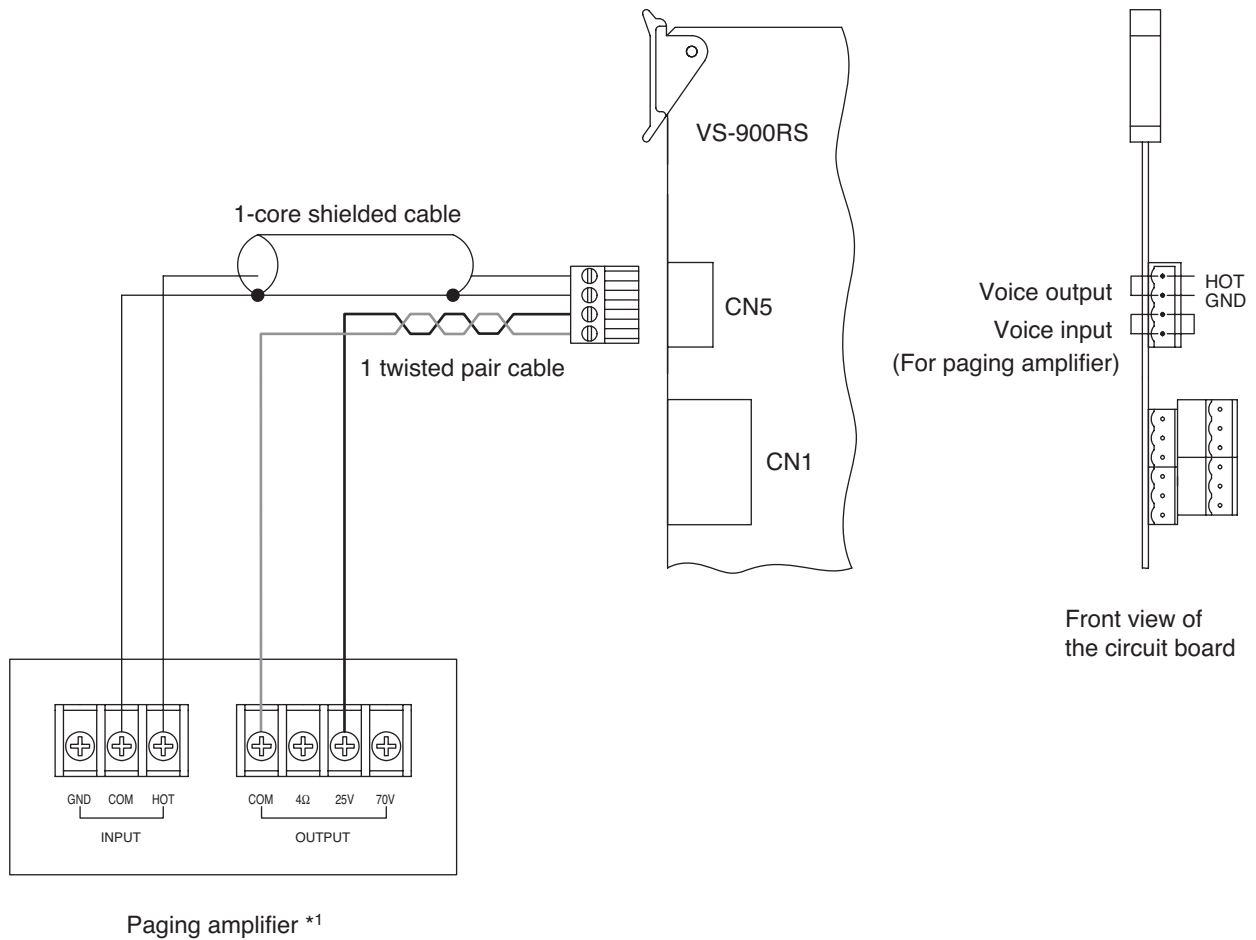

Electrical characteristics of the CN5 connector

Voice output: Unbalanced, -20 dB*2 signals to be sent to a paging amplifier

Voice input: Balanced, acceptable signals on the 25 V line output from a paging amplifier

*1 Rated at over 16 W power output (ex. TOA BG-130 30 W amplifier)

*2 0 dB = 1 V

12.7. VS-910RS Substation Interface Card Connection

RS-190 Substation and VS-910RS connection

The VS-910RS can be interfaced with up to 16 RS-190 Substations.

[Connection]

Use 2 pairs of twisted cables to connect the RS-190 and the VS-910RS. Refer to the following table for the maximum recommended cable length between the two.

Cable type	AWG24 (0.52 mm)	AWG22 (0.65 mm)	AWG20 (0.82 mm)
Distance	1 km / 3,281 ft	1.5 km / 4,921 ft	2 km / 6,562 ft

Connect as shown below.

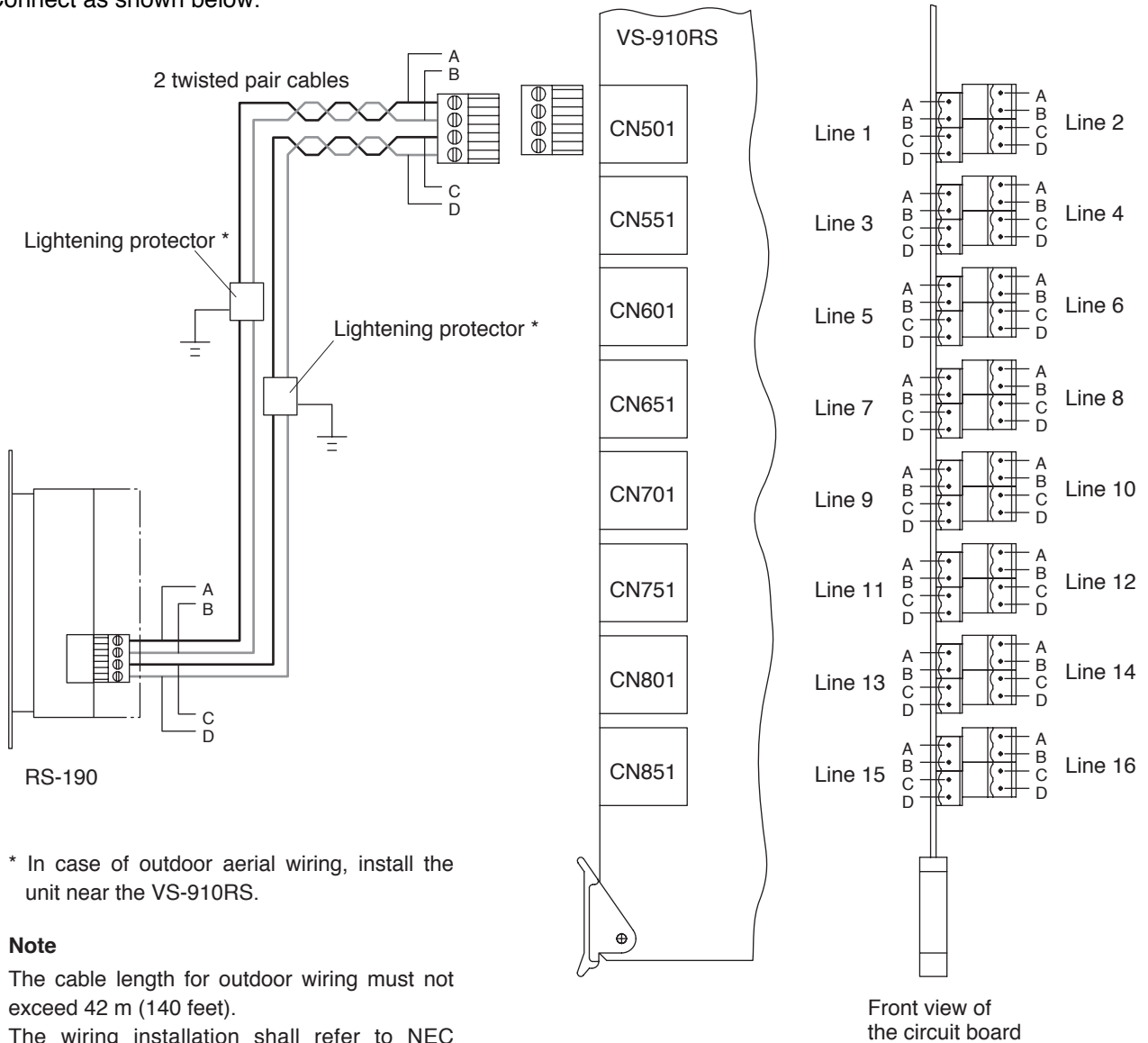

* In case of outdoor aerial wiring, install the unit near the VS-910RS.

Note

The cable length for outdoor wiring must not exceed 42 m (140 feet).

The wiring installation shall refer to NEC Articles 725 and 800.

Note

Never touch the SW301 switch (factory-preset to OFF) on the VS-910RS board.

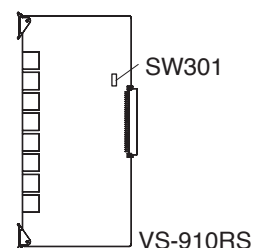

12.8. VS-900CO Outside Line Interface Card Connection

12.8.1. Outside line and VS-900CO connection

The VS-900CO can be interfaced with up to 2 outside lines. Using DTMF tone dialing, it is compatible with both loop and ground start systems.

[Connection]

Connect as shown below.

Outside line and VS-900CO connection

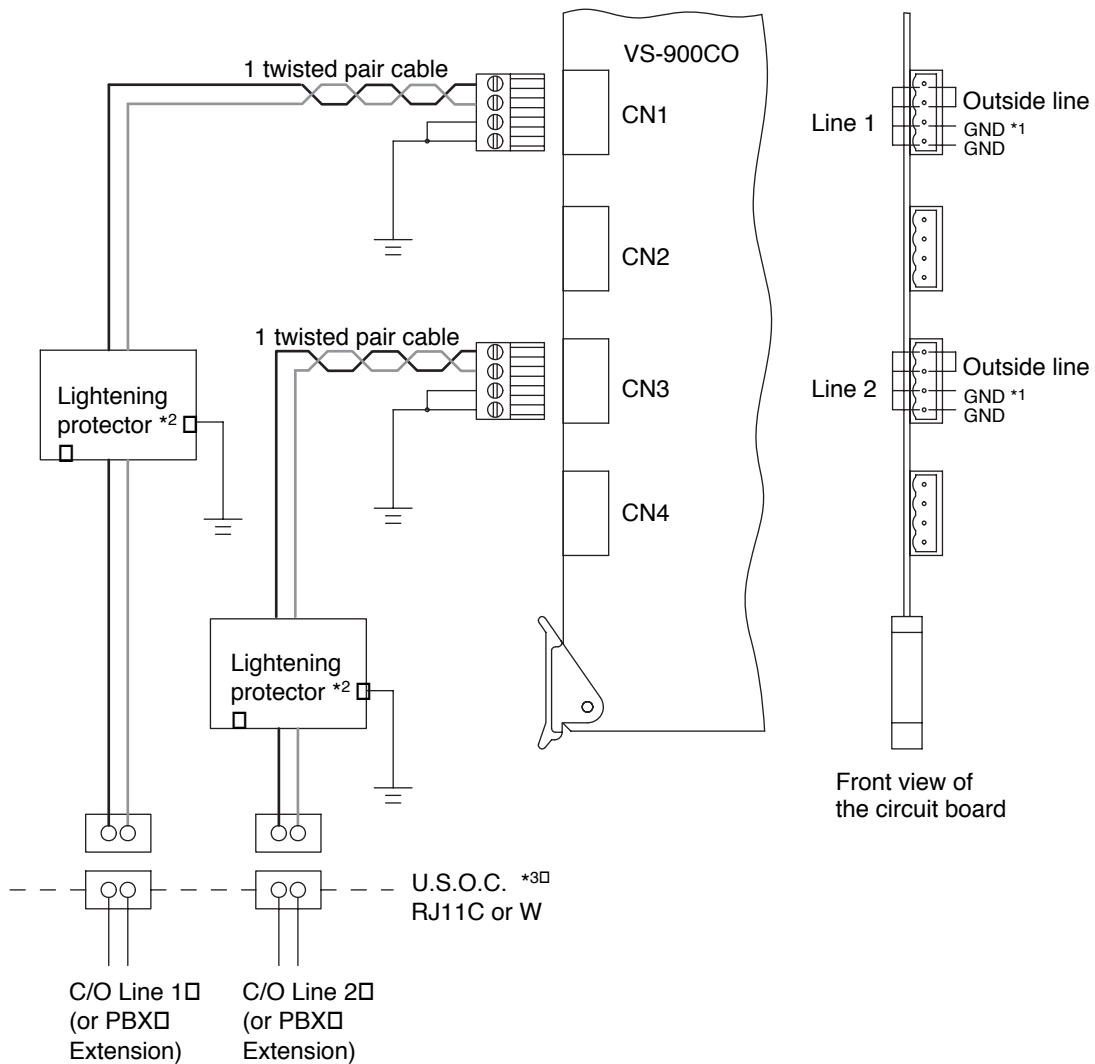

*1 Ground this terminal only when using ground start system.

*2 Install a protector if not yet installed by the telephone company.

*3 This terminal must be installed by the telephone company.

Note: Paging from the Outside Line(s) is not supported. Custom firmware for the VS-900MF must be obtained from TOA to support this special functionality.

12.8.2. External recording device and VS-900CO connection

An external recording device can be connected to each telephone line.

[Connection]

To connect the external recording device, use a twisted pair cable for audio output, and a twisted pair cable for control output. The audio output is 0 dB* and of unbalanced type. The control output is an open collector output of 20 mA, 24 V DC max. Connect as shown below.

* 0 dB = 1 V

External recording device and VS-900CO connection

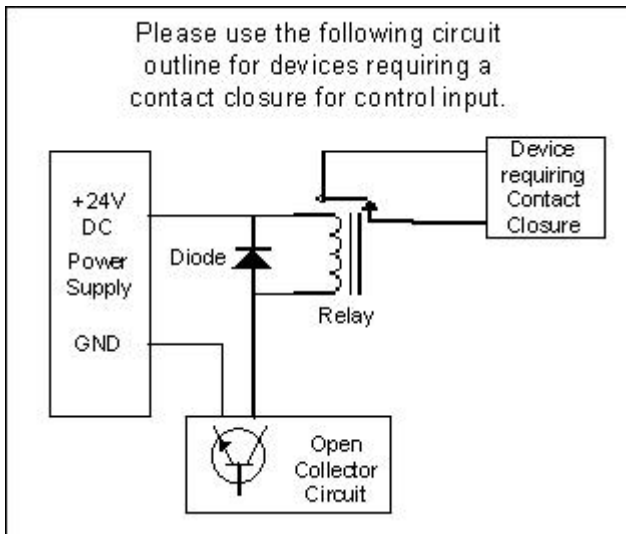
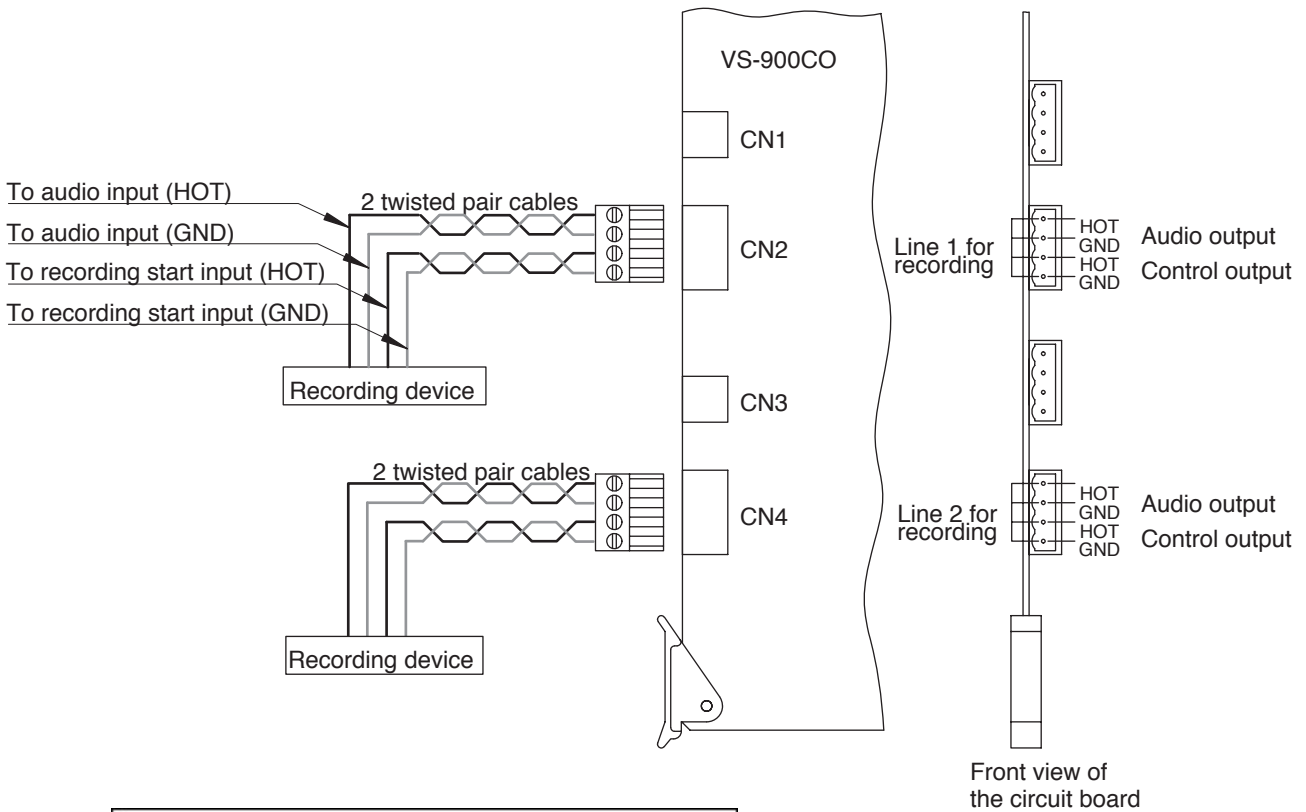

12.9. VS-900AF Audio Function Card Connection

12.9.1. Amplifier and VS-900AF connection

Paging can be provided through connected external amplifiers using the VS-900AF.

[Connection]

To connect the amplifier to the VS-900AF, use a twisted pair cable for audio output, and a twisted pair cable for control output. The audio output is 0 dB* and of unbalanced type. The control output is an open collector output of 20 mA, 24 V DC max., and permits connection of up to 16 channels. Connect as shown below.

* 0 dB = 1 V

External amplifier and VS-900AF connection

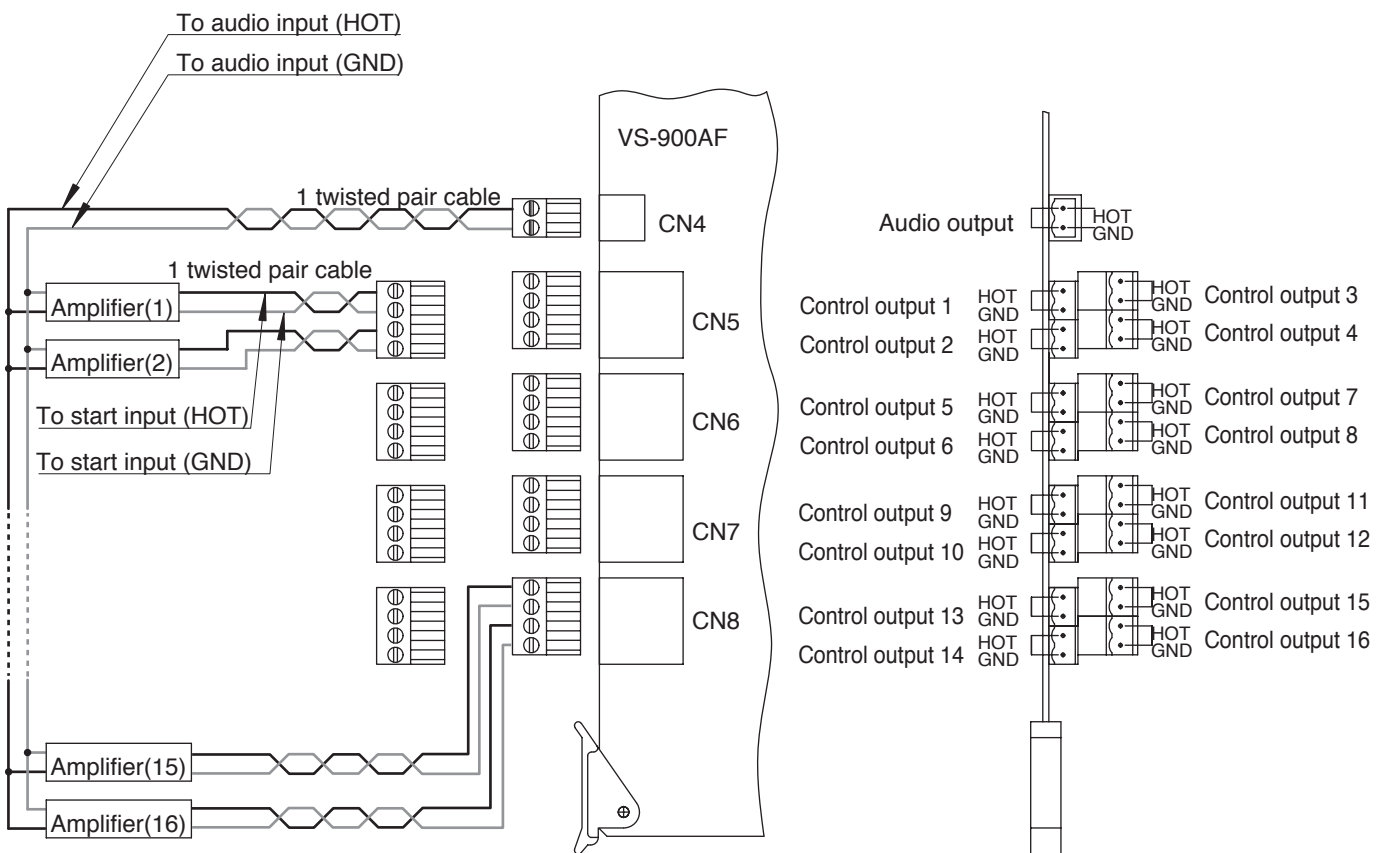

Front view of the circuit board

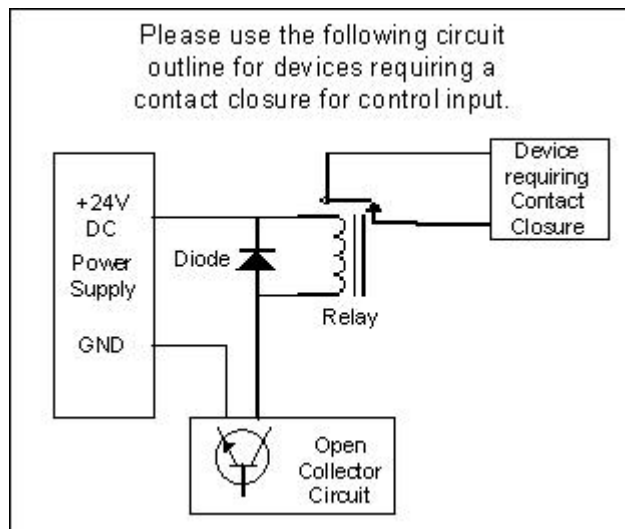

12.9.2. External sound source and VS-900AF connection

The External Sound Source Distribution function can be operated using the VS-900AF.

[Connection]

To connect external sound sources to the VS-900AF, use a twisted pair cable for audio input, and a twisted pair cable for control input (level-operated activation). The audio input is 0 dB* and of unbalanced type. The control start input is a no-voltage make contact of 20 mA, 24 V DC max. Connect as shown below.

* 0 dB = 1 V

External sound sources and VS-900AF connection

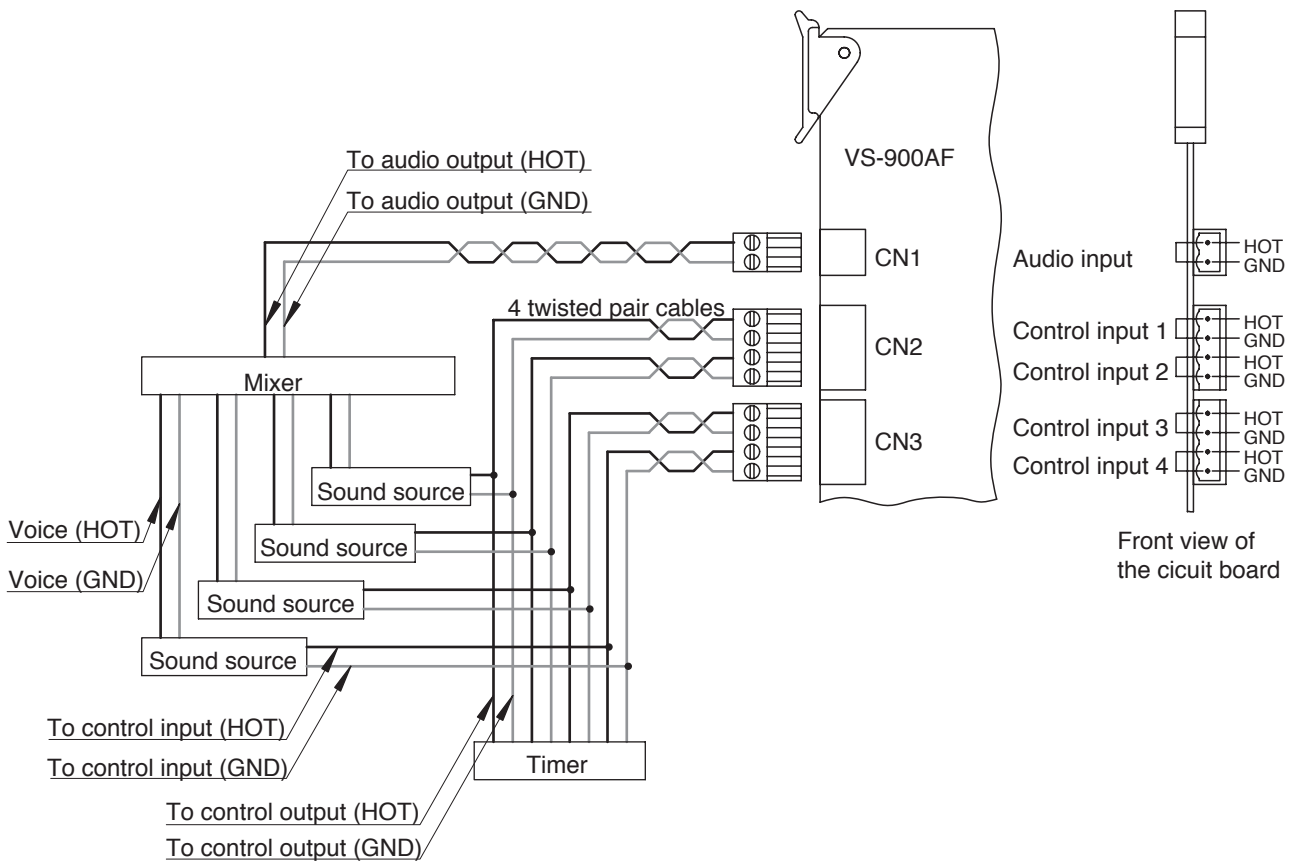

- Notes: 1) VS-900AF control input requires a contact closure for the duration of the event.
 2) Isolated relay contacts may be required for the "Timer" control output to trigger both the sound source and control input of the VS-900AF. (Example: DPDT type relay.)

12.10. VS-900TI Tie-Line Interface Card Exchange Interconnection

Up to 16 exchanges can be tie-line interconnected using the VS-900TI card.

[Connection]

To interconnect the exchanges, use 2 twisted pair cables for voice tie-lines (CN1, CN2, CN3 & CN4), and an (STP) shielded, twisted pair cable for data lines (CN6). A maximum of 4 audio tie-lines can be connected. Refer to the following table for the maximum recommended length for each cable type between exchanges. (As to the cable connection, see the figure on the next page.)

Cable type	AWG24 (0.52 mm)	AWG22 (0.65 mm)	AWG20 (0.82 mm)
Distance	0.6 km / 1,968 ft	1 km / 3,281 ft	1.5 km / 4,921 ft

[Termination resistance setting]

When interconnecting three or more exchanges, change the SJP10 connection on each card as shown below, with the exception of the cards in the first and last exchanges.

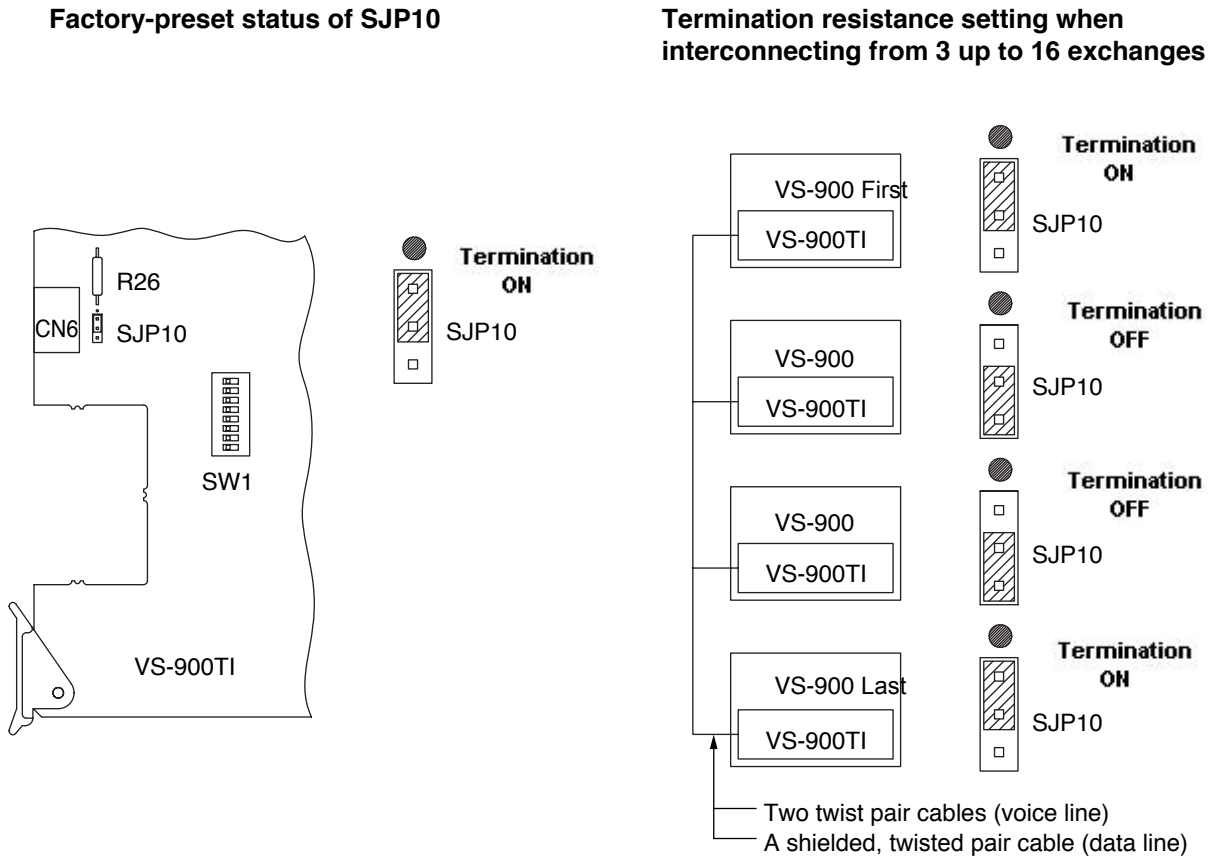

Connect as shown below.

Exchange interconnection by means of VS-900TI

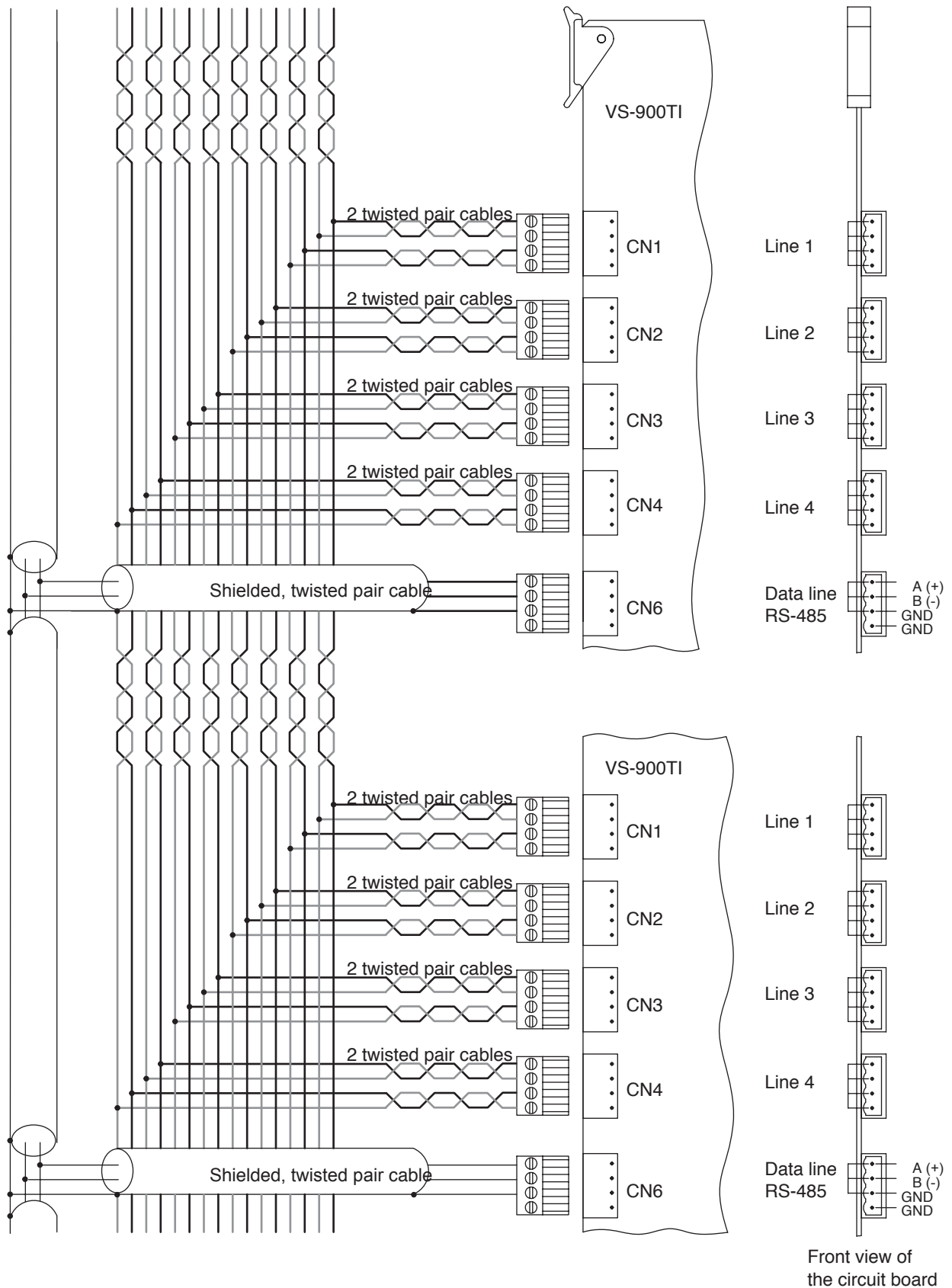

[Exchange Number Setting]

When interconnecting the exchanges using the VS-900TI, assign the exchange number to each exchange with the SW1 switch located on the VS-900TI's circuit board. (Refer to the table below.)

Exchange No. setting

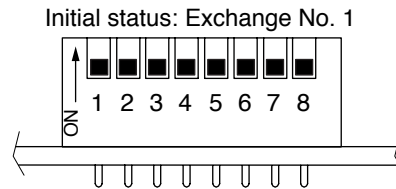
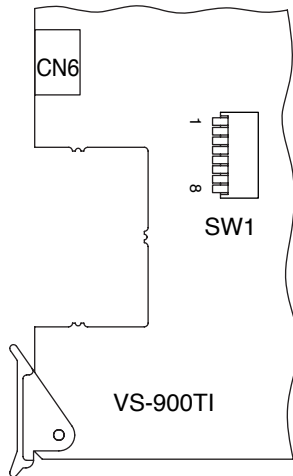

Exchange No.	1	2	3	4	5 - 8
1	OFF	OFF	OFF	OFF	OFF
2	ON	OFF	OFF	OFF	OFF
3	OFF	ON	OFF	OFF	OFF
4	ON	ON	OFF	OFF	OFF
5	OFF	OFF	ON	OFF	OFF
6	ON	OFF	ON	OFF	OFF
7	OFF	ON	ON	OFF	OFF
8	ON	ON	ON	OFF	OFF
9	OFF	OFF	OFF	ON	OFF
10	ON	OFF	OFF	ON	OFF
11	OFF	ON	OFF	ON	OFF
12	ON	ON	OFF	ON	OFF
13	OFF	OFF	ON	ON	OFF
14	ON	OFF	ON	ON	OFF
15	OFF	ON	ON	ON	OFF
16	ON	ON	ON	ON	OFF

12.11. VS-900SC Site Connector Connection

12.11.1. Exchange connection example

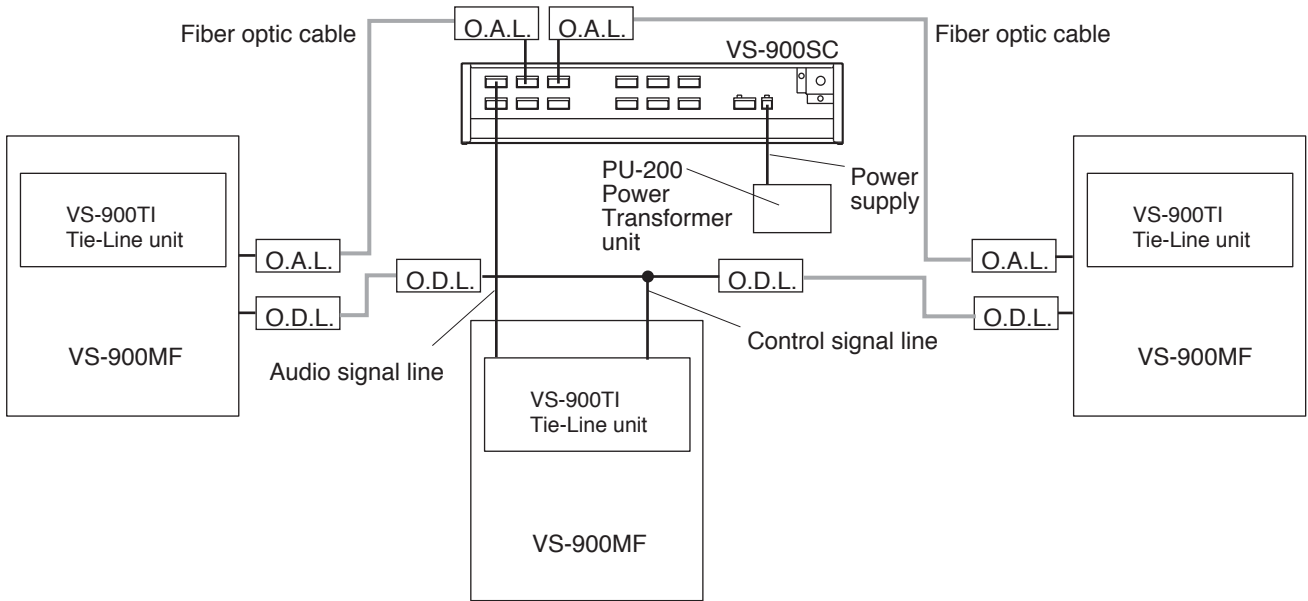

* O.A.L. (Optical Analog Link): Optical/audio signal converter
 O.D.L. (Optical Data Link): Optical/digital signal converter

- For the optical/audio signal converter, prepare one which can transmit a 600 Ω , 0 dBm signal.
- For the optical/digital signal converter, prepare one which can convert an RS-485 signal into an optical signal.
- Prepare the power source separately.

12.11.2. VS-900SC Power supply connection

Connect the optional PU-200 power transformer unit as shown below:

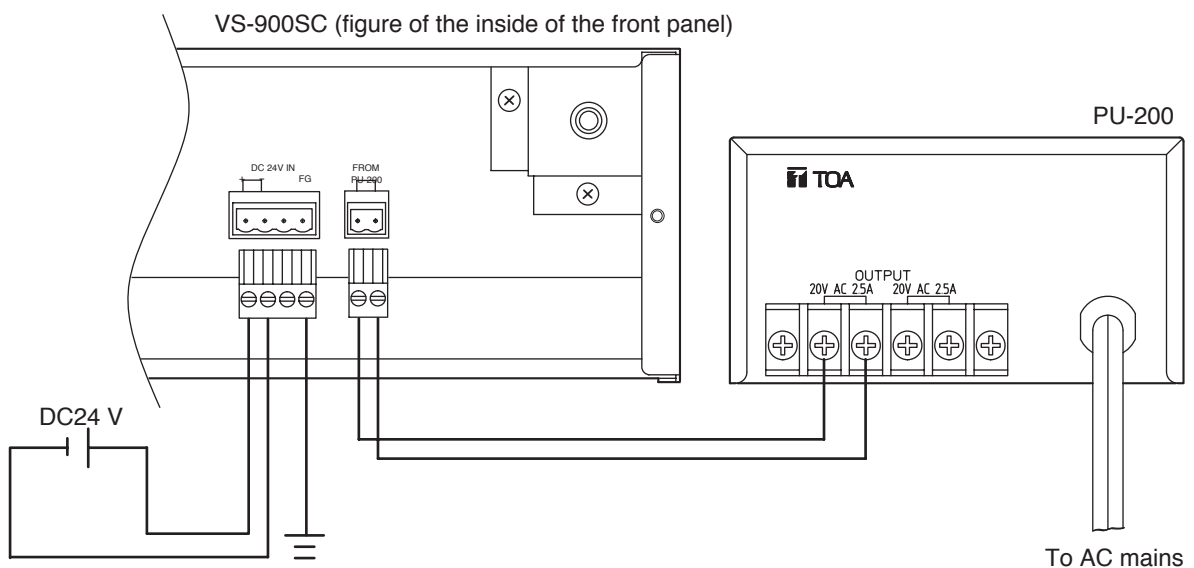

Connect the backup power supply, if needed, to the VS-900SC's DC input as illustrated.

Note: The backup power supply should be a UL Listed Limited Power Source or Class 2 power supply, rated 24 V DC, 0.2 A.

12.11.3. VS-900SC connection to the VS-900TI

Connect each connector of the unit's Voice Lines 1 – 4 to the corresponding connector on the VS-900TI's CN 1 – 4. Pins No. 1 and 2 of each connector of Voice Lines 1 – 4 are for receiving ends, while pins No. 3 and 4 are for transmitting ends. Use 2 twisted pair cables for connection as shown below.

VS-900SC (figure of the inside of the front panel)

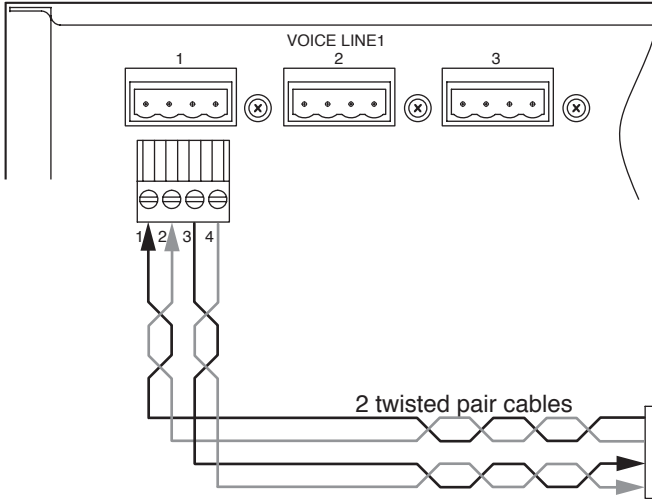

VS-900TI Connection with VS-900SC	
VS-900TI Connector	VS-900SC Connector
CN1	Voice Line 1 - 1
CN2	Voice Line 2 - 1
CN3	Voice Line 3 - 1
CN4	Voice Line 4 - 1

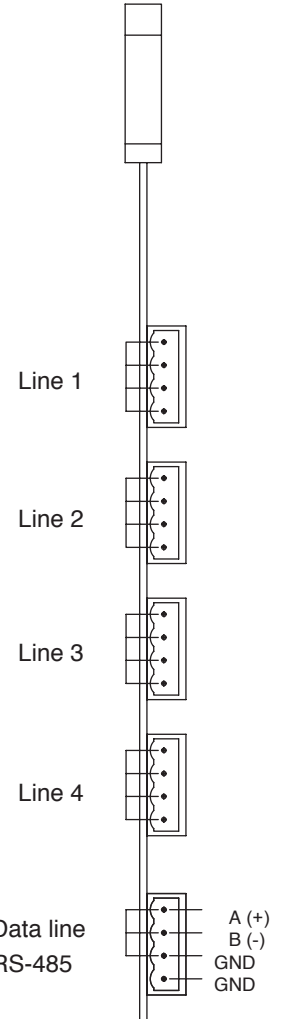
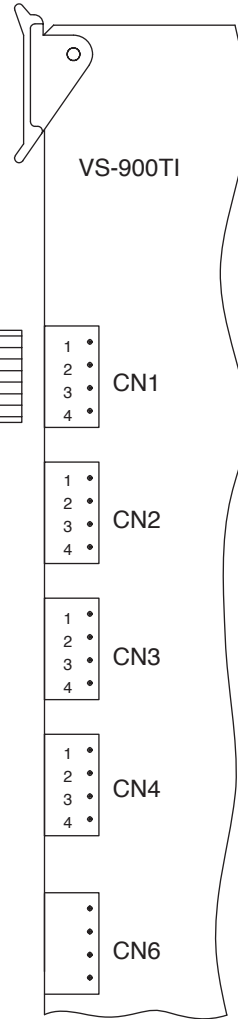

- For the VS-900TI, cut SJP of each line to be connected.

- Line 1: LINK1-1 (SJP13) and LINK1-2 (SJP14)
- Line 2: LINK2-1 (SJP15) and LINK2-2 (SJP16)
- Line 3: LINK3-1 (SJP17) and LINK3-2 (SJP18)
- Line 4: LINK4-1 (SJP19) and LINK4-2 (SJP20)

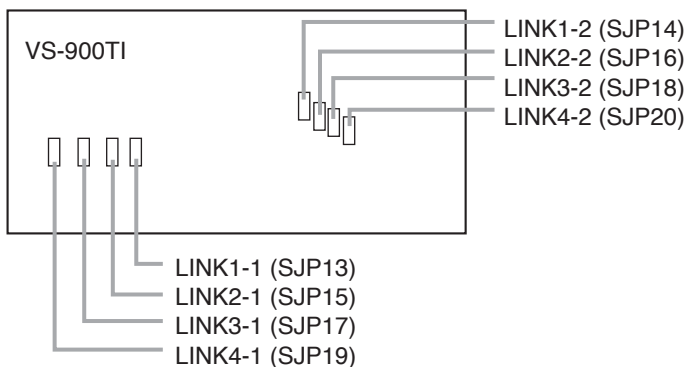

Front view of the circuit board

Note: RS-485 Data Line (CN6) does not connect to the VS-900SC Site Connector.

12.11.4. Connecting the VS-900SC to another VS-900SC unit

Connect individual Voice Lines 1 – 4 connectors to each other.

Pins No. 1 and 2 of each connector of Voice Lines 1 – 4 are for receiving ends, while pins No. 3 and 4 are for transmitting ends. Use 2 twisted pair cables to make connections as shown below.

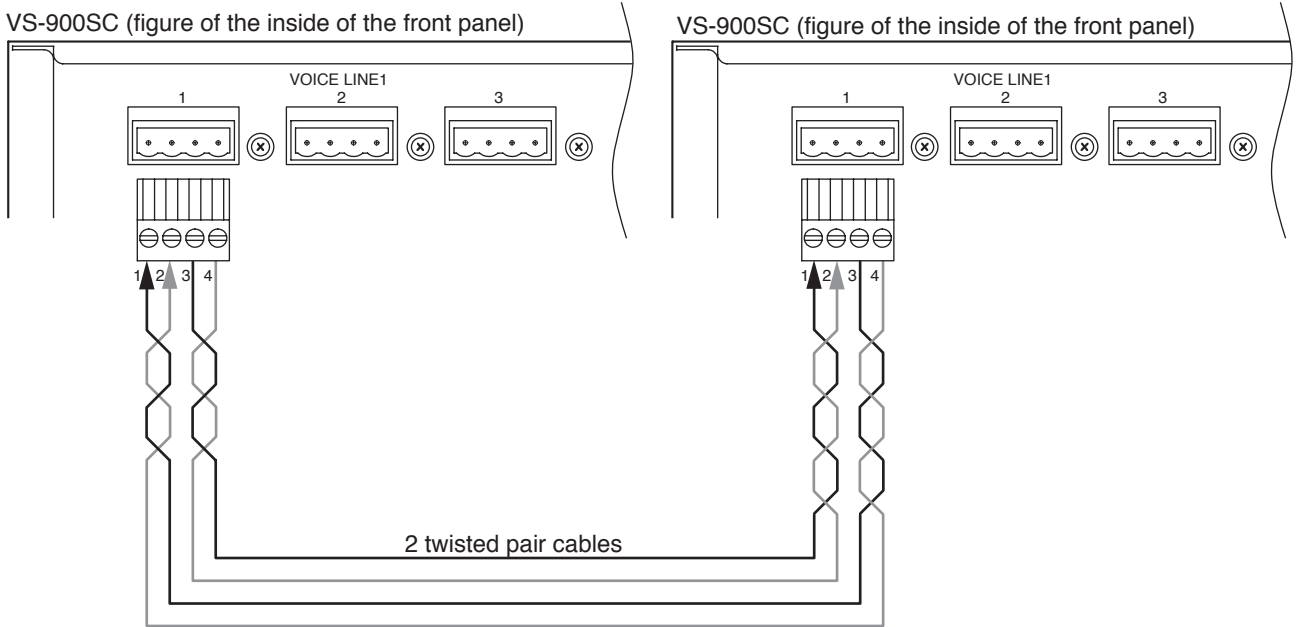

12.11.5. Connection to an optical fiber / audio signal converter

Connect the optical fiber / audio signal converter to each connector of Voice Lines 1 – 4.

Pins No. 1 and 2 of each connector of Voice Lines 1 – 4 are for receiving ends, while pins No. 3 and 4 are for transmitting ends. Use 2 twisted pair cables to make connections according to the specifications of the optical fiber equipment to be connected.

12.12. VS-900MF Main Frame and PU-200 Power Transformer Connection

[Connection]

Connect as shown below using 2 parallel pair cables. Use cables with a sufficient current capacity and a heavier gauge than AWG18. Two PU-200 units are required when using 3 or 4 VS-900RS cards. Connect the backup power supply, if needed, to the VS-900MF's DC input as illustrated.

VS-900MF and power supply connection

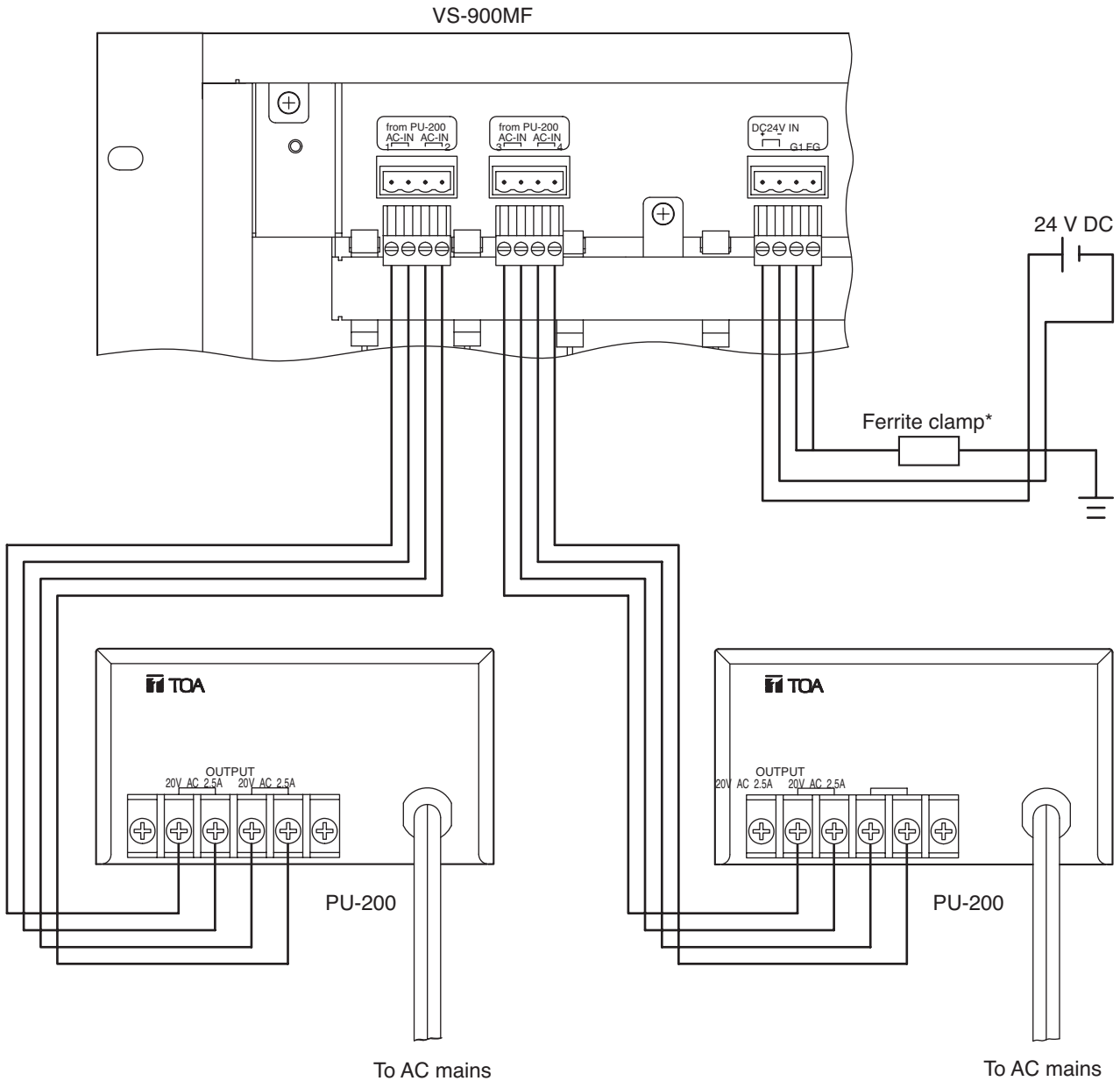

* Mount the ferrite clamp (supplied with the VS-900MF) on the cable in a way that the cable is looped one turn as illustrated. (This countermeasure is for complying with the CE marking and FCC requirements.)

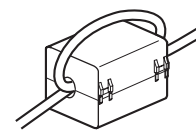

Ferrite clamp
SFC-10

13. MAIN FRAME AND PC CONNECTION

13.1. Programming PC Connection

13.1.1. Direct connection by means of RS-232C

Using the RS-232C cable, connect the programming PC to the VS-900MF Main Frame as shown below.

Direct connection by means of RS-232C (Programming PC)

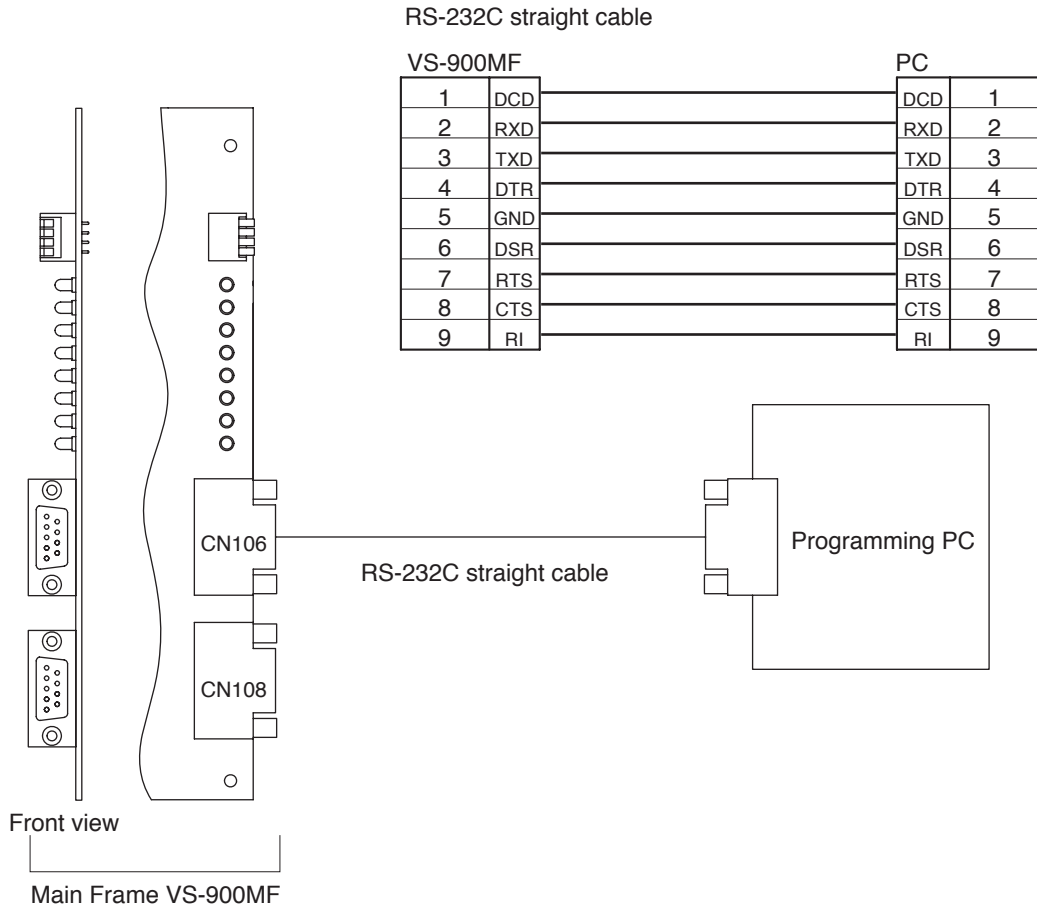

13.1.2. Connection via modem

Connect as shown below.

Connection via modem (Programming PC)

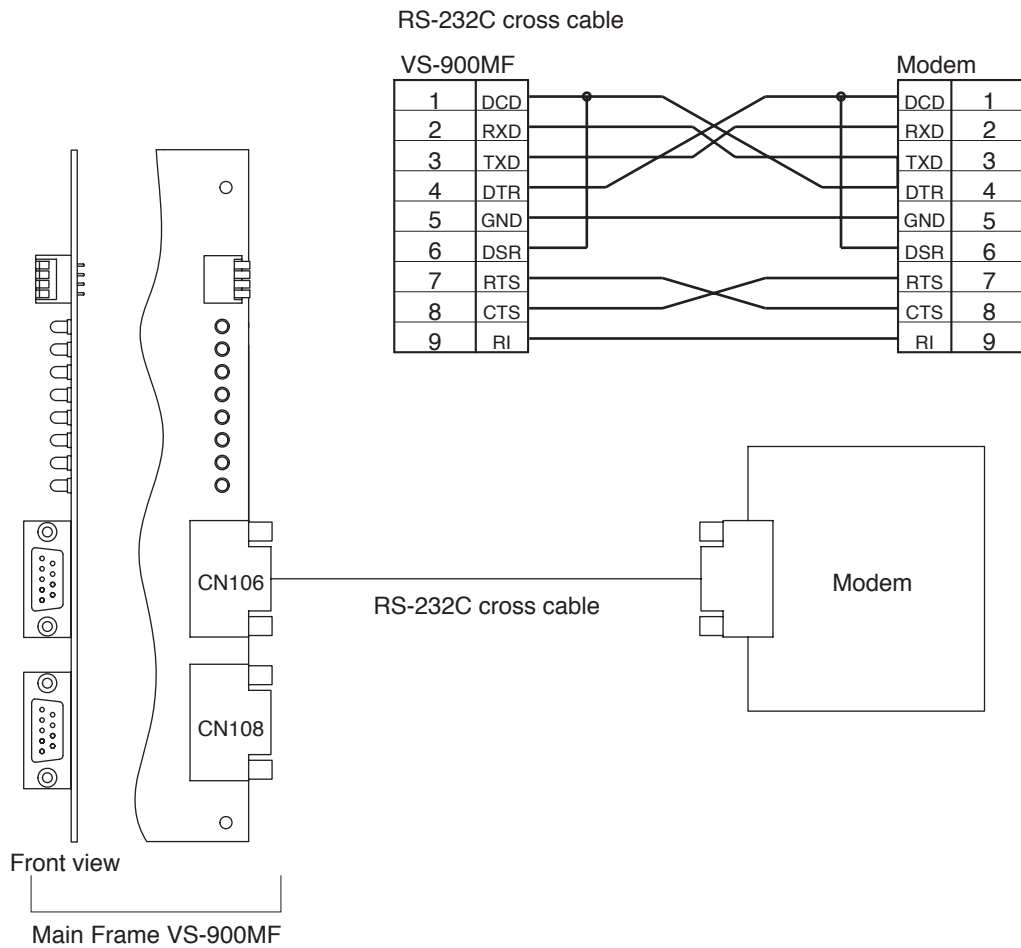

13.2. Operation Log PC Connection

13.2.1. Direct connection by means of RS-232C

Using the RS-232C cable, connect the operating log PC to the VS-900MF as shown below.

Direct connection by means of RS-232C (Operation log PC)

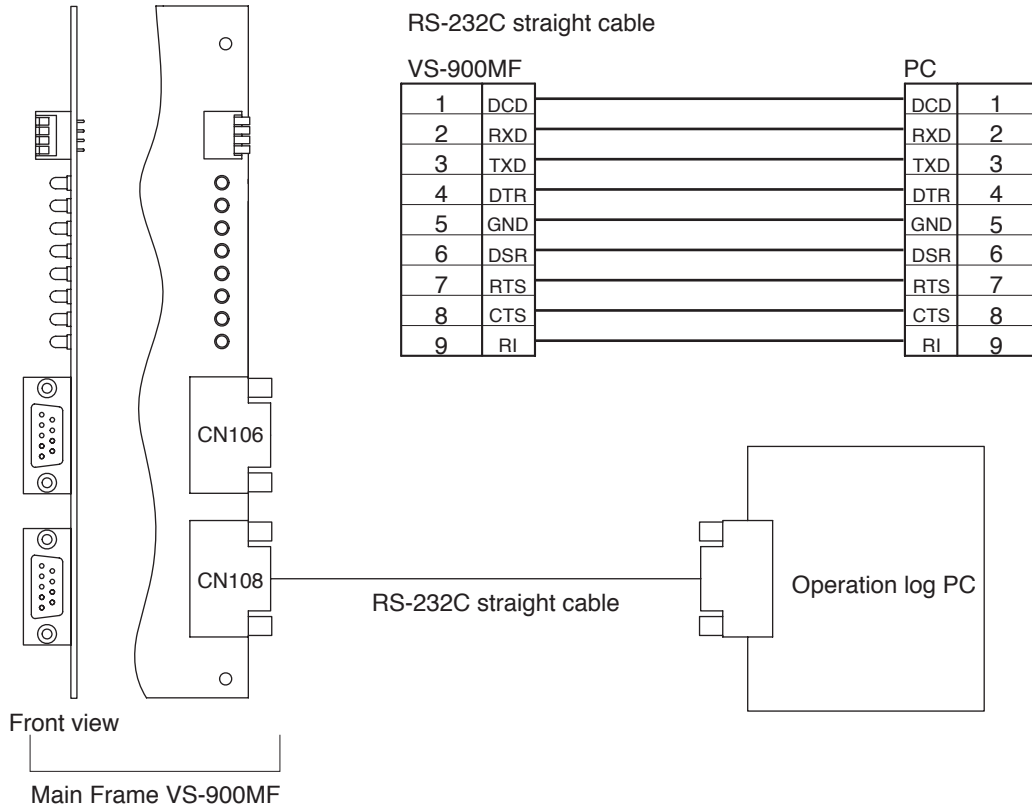

13.2.2. Connection via modem

Connect as shown below.

Connection via modem (Operation log PC)

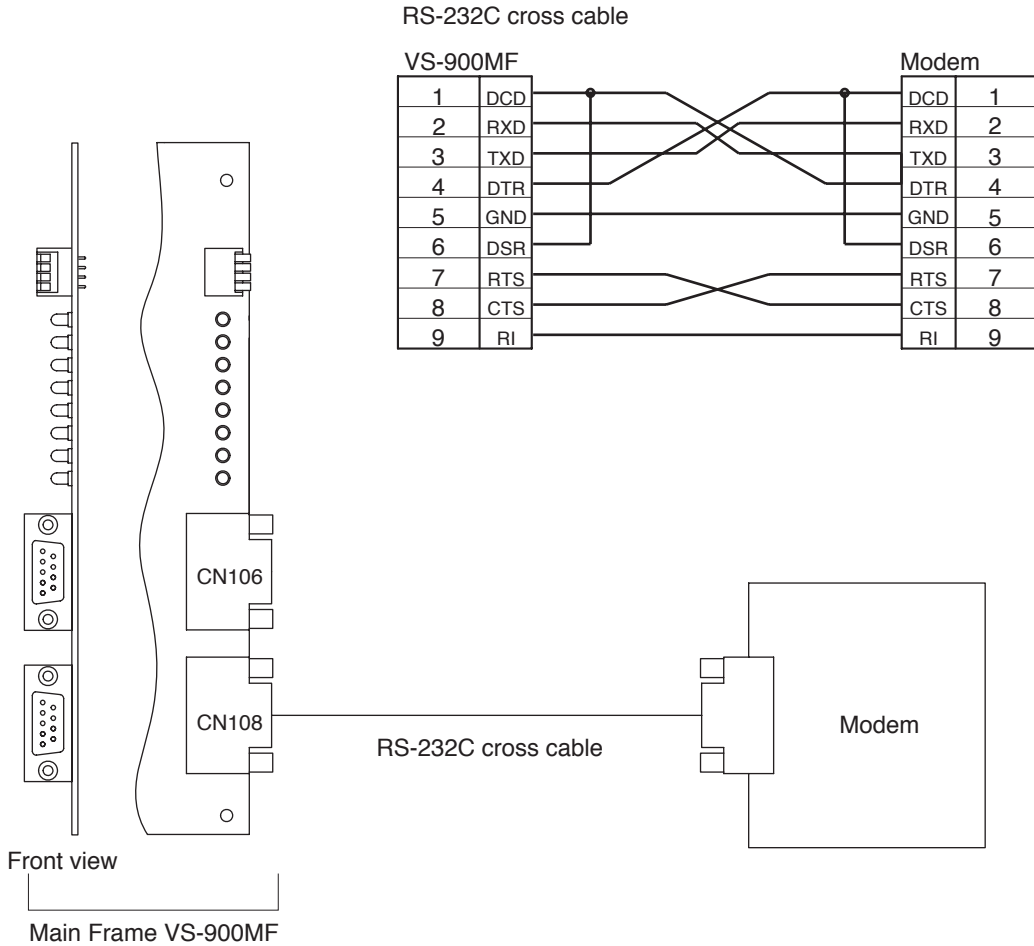

13.3. System Programming

Use the supplied PC software to perform such system programming as: system clock time, station number and function settings. For its use and installation, refer to the "VS-900 Setup Software Instruction Manual."

14. SPEECH AND FUNCTION TESTS

Using installed equipment, perform both speech and function tests after system programming completion.

14.1. Speech Test

(1) Calls from the substation

- Call the Master Station (telephone) from each substation to check to be sure that a conversation is possible. Also, check to confirm that the master station (telephone) registered in system programming is correctly called.
- Check to be sure that the calling substation number (name) is correctly displayed on the Master Station.

(2) Calls from the master station

- Call the substation and Master Station from each Master Station to check to be sure that a conversation is possible.
- Check to confirm that the designated station is correctly called.

14.2. Function Test

Check each function registered in system programming for correct operation.
For each function's operation, refer to the "VS-900 OPERATING INSTRUCTIONS."

15. SPECIFICATIONS

[VS-900MF Main Frame]

Power Source	20 V AC, 24 V DC
Current Consumption	7 A
Speech Path Configuration	Time sharing switch (T1 stage)
Serial port	Complies with the RS-232C Standard, D-sub connector (9-pin, female), 2 ports
Installation Method	Rack- and wall-mountable
Other	Real time clock for time control Unit's presence/non-presence detection System programming data maintenance Power switch
Connection Terminal	Bus connector: DIN connector (64-pin, female) x 9 PU-200 connection terminal: 4-pin x 2 (2 PU-200s are connectable.) 24 V DC input terminal: 4-pin (with grounding terminal)
Operating Temperature	0 to +40°C
Finish	Pre-coated steel plate, black, 30% gloss
Dimensions	420 (w) x 443.7 (h) x 288.3 (d) mm (excluding the rack mounting bracket)
Weight	12.7 kg

Note: The design and specifications are subject to change without notice for improvement.

• Accessories

Rack mounting bracket	2	VS-900 operating instructions	1
Machine screw (M4 x 10)	6	VS-900 installation manual (this manual)	1
Cable clip	20	VS-900 setup software manual	1
4-pin dedicated connector	3	Rack mounting screw	8
CR2032 battery	1	Rack mounting washer	8
Floppy disk (PC setting software)	2	Ferrite clamp SFC-10	1

[VS-900MS Master Station Interface Card]

Power Source	5 V DC, 24 V DC (supplied from the main frame)
Current Consumption	50 mA (5 V DC), 200 mA (24 V DC)
Supply Power	24 V DC, 80 mA
Number of Lines	2 lines
Conversation Recording Output	Audio signal: 0 dB*, unbalanced Control signal: Open collector output, withstand voltage: 24 V DC, control current: 20 mA
Other	Master station connection monitoring function
Connection Terminal	Main frame connection side: DIN connector (64-pin, male) Line output: 4-pin x 2 Recording audio/control output: 4-pin x 2
Operating Temperature	0 to +40°C
Weight	350 g

* 0 dB = 1 V

Note: The design and specifications are subject to change without notice for improvement.

• Accessories

4-pin dedicated connector	4
Ferrite clamp SFC-10	2

[VS-900AL Telephone Interface Card]

Power Source	5 V DC, 15 V DC, 24 V DC (supplied from the main frame)
Current Consumption	150 mA (5 V DC), 30 mA (15 V DC), 200 mA (24 V DC)
Supply Power	24 V DC, 80 mA
Number of Lines	2 lines
Conversation Recording Output	Audio signal: 0 dB*, unbalanced Control signal: Open collector output, withstand voltage: 24 V DC, control current: 20 mA
Selectable Signal Type	DTMF signal
Monitoring Function	Line loop detection function
Applicable Terminal	Telephone sets to comply with FCC Part 68
Control Function	Call signal transmission, audible signal transmission, caller identification signal transmission (Caller ID Function)
Connection Terminal	Main frame connection side: DIN connector (64-pin, male) Line output: 2-pin x 2 Recording audio/control output: 4-pin x 2
Operating Temperature	0 to +40°C
Weight	400 g

* 0 dB = 1 V

Note: The design and specifications are subject to change without notice for improvement.

• Accessories

2-pin dedicated connector	2
4-pin dedicated connector	2
Ferrite clamp SFC-10	2

[VS-900RS Remote Sub-station Interface Card]

Power Source	5 V DC, 24 V DC (supplied from the main frame)
Current Consumption	200 mA (5 V DC), 600 mA (24 V DC)
Number of Lines	Substation 16 lines
Number of Links	2 links (One of 2 links is also used as a Paging Link.)
Paging Output	-20 dB*, 1 kΩ, unbalanced
Paging Input	25 V line, balanced
Conversation Method	Half-duplex conversation by voice-operated switch or simplex conversation by PTT switch
Audio Output	Maximum 1 W per substation
Supply Power	Maximum 15 V/20 mA per substation
Other	Call button detection function and speech link control function
Connection Terminal	Main frame connection side: DIN connector (64-pin, male) Substation connection side: Two-core shielded cable (3-pin) x 16 Paging input/paging output: 4-pin
Operating Temperature	0 to +40°C
Weight	550 g

* 0 dB = 1 V

Note: The design and specifications are subject to change without notice for improvement.

• Accessories

3-pin dedicated connector	16
4-pin dedicated connector	1

[VS-910RS Remote Sub-station Interface Card]

Power Source	5 V DC, 24 V DC (supplied from the main frame)
Current Consumption	5 V DC: 200 mA 24 V DC: 600 mA (maximum during normal use), 1.5 A (maximum when 16 lines are simultaneously shorted)
Number of Lines	Substation 16 lines
Number of Links	2 links (one of 2 links is also used as a Paging Link.)
Conversation Method	Full-duplex conversation or Half-duplex conversation by voice-operated switch
Audio Output	Maximum 1 W per substation
Supply Power	Maximum 20 V/30 mA per substation
Control System	Two-way dial pulse width system (call, restoration, external control, etc.) by current loop
Connection Terminal	Main frame connection side: DIN connector (64-pin, male) Substation connection side: 4-pin x 16
Connection Monitoring Function	Line connection detection, line short circuit/open circuit/failure detection, and communication irregularity detection
Operating Temperature	0 to +40°C
Weight	700 g

* 0 dB = 1 V

Note: The design and specifications are subject to change without notice for improvement.

• **Accessories**

4-pin dedicated connector 16

[VS-900CO Outside Line Interface Card]

Power Source	5 V DC, 15 V DC, 24 V DC (supplied from the main frame)
Current Consumption	300 mA (5 V DC), 50 mA (15 V DC), 50 mA (24 V DC)
Number of Lines	2 lines
Conversation Recording Output	Audio signal: 0 dB*, unbalanced Control signal: Open collector output, withstand voltage: 24 V DC, control current: 20 mA
Selectable Signal Type	DTMF signal
Signal Format	Loop start and Ground start compatible
Main Functions	DTMF dial signal transmission function, DTMF signal detection function, call signal (receiving) detection
Connection Terminal	Main frame connection side: DIN connector (64-pin, male) C/O line connection side: 4-pin x 2 Recording audio/control output: 4-pin x 2
Operating Temperature	0 to +40°C
Weight	380 g

* 0 dB = 1 V

Note: The design and specifications are subject to change without notice for improvement.

• **Accessories**

4-pin dedicated connector 4

[VS-900AF Audio Function Card]

Power Source	5 V DC, 15 V DC, 24 V DC (supplied from the main frame)
Current Consumption	170 mA (5 V DC), 50 mA (15 V DC), 30 mA (24 V DC)
Paging Output	Audio output: 1 output, 0 dB*, unbalanced Control output: Open collector output, withstand voltage: 24 V DC, control current: 20 mA
External Source Distribution	Audio input: 1 input, 0 dB*, unbalanced Control input: 4 inputs, no-voltage make contact, open voltage: 24 V DC, short circuit current: 20 mA
Conference Link	1 link (up to 4-party conference)
Connection Terminal	Main frame connection side: DIN connector (64-pin, male) External interface side: Audio output 2-pin Control output 2-pin x 16 Audio input 2-pin Control input 2-pin x 4
Operating Temperature	0 to +40°C
Weight	230 g

* 0 dB = 1 V

Note: The design and specifications are subject to change without notice for improvement.

• **Accessories**

- 2-pin dedicated connector 2
- 4-pin dedicated connector 10

[VS-900TI Tie-Line Interface Card]

Power Source	5 V DC, 15 V DC (supplied from the main frame)
Current Consumption	100 mA (5 V DC), 50 mA (15 V DC)
Number of Audio Links	4 links
Connection Format	Multidrop system
Transmitting System	Data: RS-485 Voice: Base band
Input/Output Level	Data: In compliance with RS-485 Standard Voice: 0 dB*, balanced
Other	Exchange number setting function
Connection Terminal	Main frame connection side: DIN connector (64-pin, male) Tie-line interface side: 4-pin x 4 (Voice line), 4-pin x 1 (Data line)
Operating Temperature	0 to +40°C
Weight	320 g

* 0 dB = 0.775 V

Note: The design and specifications are subject to change without notice for improvement.

• **Accessories**

- 4-pin dedicated connector 5

[VS-900SC Site Connector]

Power Source	20 V AC (supplied from the power transformer unit, under 250 mA) 24 V DC (UL Listed Limited Power Source or Class 2 power supply, rated 200 mA)
Name of Links	4 links
Input	0 dB*, 600 Ω, balanced (transformer)
Output	0 dB*, 600 Ω, balanced (transformer)
Installation Method	Rack- and wall-mountable
Connection Terminal	Voice line side: 4-pin x 3 (voice line)/1 link PU-200 connection terminal: 2-pin 24 V DC input terminal: 4-pin
Operating Temperature	0 to +40°C
Finish	Panel, Case: Pre-coated steel plate, black
Dimensions	420 (w) x 88.4 (h) x 238 (d) mm
Weight	3.55 kg

* 0 dB = 0.775 V

Note: The design and specifications are subject to change without notice for improvement.

• Accessories

Rack-mounting bracket	2	Link plate	2
Rack mounting screw 5 x 12	4	Screw 4 x 12	2
Fiber washer M5	4	Tapping screw 3 x 12	8
Wall-mounting bracket	2	Connector (4-pin)	13
Wood screw 4.1 x 20	4	Connector (2-pin)	1

[YC-303 Main Frame Wall Mounting Bracket]

Finish	Steel, black, electrodeposition paint
Dimensions	391.4 (w) x 440 (h) x 58 (d) mm
Weight	2.1 kg

Note: The design and specifications are subject to change without notice for improvement.

• Accessories

Wood screw (5.1 x 38)	4
Tapping screw (4 x 12)	4

